

TECHNICAL NOTE

Number: VX-TN-12K.1A
First Issue: Sept 2005
Revised: Nov 2005

Vinidex Pty. Limited
ABN 42 000 664 942
19-21 Loyalty Rd., (PO Box 4990)
North Rocks, NSW. 2151, Australia

THRUST SUPPORT OF VALVES

This technical note addresses only technical matters related to the application of our products. It does not address issues of health and safety practices, nor any regulatory limitations that may apply, and does not constitute a recommendation of suitability for any purpose

Introduction

Valves are subjected to pressure thrust when closed, wholly or partially. In rigidly jointed systems where the joints are able to carry tension loads, it is usual to allow the pipe to carry the thrust. In flexibly jointed elastomeric gasketed systems (without thrust restraining devices), this of course is not possible. A simple alternative is to allow the pipe downstream to support the thrust in compression, but this is not without its problems. The more complete solution is to provide independent thrust support via an anchor block to transfer the thrust to the soil, or adjacent frame work for above ground systems. Clearly there is a cost associated with this.

Specifications

In general, specifications require independent thrust support, and this is the case with European¹, American² and International³ installation standards. In fact, in a survey of 18 other world wide specifications and recommendations from water agencies, research institutions and manufacturers to be found on the Internet, all required independent support of valves for sizes above 65 mm.

Australian Standards also specify restraint of valves, in AS 2032⁴ since 1977, and more recently in the installation provisions of AS/NZS 2566⁵.

However some authorities in Australia do not thrust-block valves up to DN250, and the Water Supply code of Australia, WSA 03⁶ permitted this practice, although an amendment⁷ has now been issued.

Technical discussion

The technical reasons for independent thrust support are both general to all pipes and specific to rubber ring joint thermoplastic systems:

Axial thrust is developed by unequal pressures on either side of a valve whenever it is closed. The magnitude (Table 1) is surprising:

Table 1: Thrust developed on closed valves.

DN (series 2)	Thrust (tonnes equivalent)	
	At 1 MPa working pressure	At PN 16 test pressure
80	0.7	1.5
100	1.2	2.4
150	2.5	5.1
200	4.3	8.6
225	5.4	10.7
250	6.6	13.1

Consideration needs to be given to the means of providing safe and reliable reaction to this thrust.

Support is also required against torque, which may be considerable, when opening or closing valves.

Thrust support is normally provide by a concrete thrust block, typically as in Fig 1. Some specifications allow a simpler arrangement using railway sleepers or similar spanning the trench and cut into the sides.

Fig 1: Typical Cast-in-place concrete thrust support (reproduced from WSA 03)

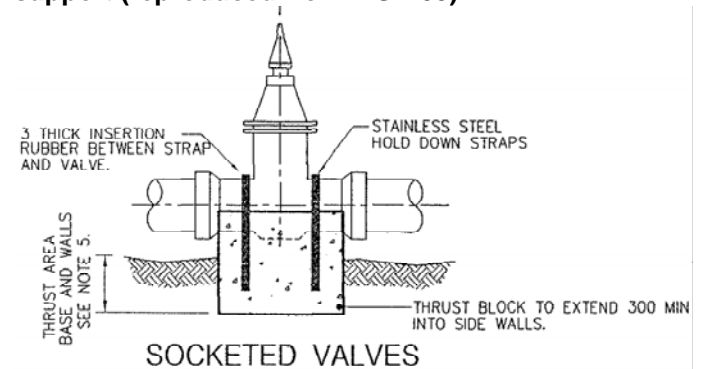

If provision is not made for independent thrust and torque reaction, these forces will be transferred to the ends of the adjacent pipes. The potential issues are:

- Valve to pipe thrust transfer:

Damage to protective coatings and linings, or to pipe spigots may occur. Damage may be exacerbated by point loading on spigots that are not cut square, or angular deflection between pipe and socket (Figs 2 & 3). Movement of the valve with pressure reversal is likely to cause damage, and may disturb the seal. Rotation of the valve under torque may also may cause damage or leakage.

Fig 2: Effect of angular deflection (3 degrees) and load concentration.

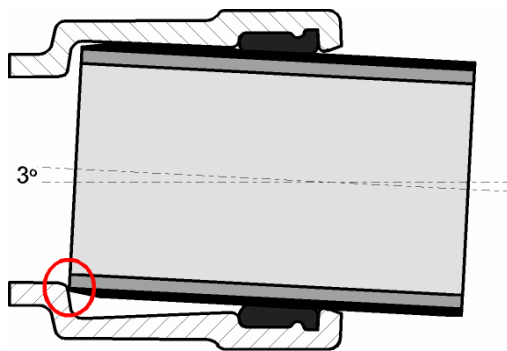

Fig 3: Spigot damage to PVC-O500 PN16 DN100 at 18 kN (1.8 tonnes eq) axial load



• **Down stream thrust transfer:**

The axial thrust from the valve must be transferred to the soil by friction, requiring a significant length of pipe downstream, poorly predictable. Fig 4 shows an estimate of the number of 6 m lengths of pipe necessary to absorb the thrust due to a 1 MPa pressure in granular surround, 0.75 m cover. Even for DN100 the thrust must be transferred through one downstream joint, and for larger sizes, many. The problem of cut pipes must be considered too.

Standard formed PVC pipe joints are not designed to transmit compressive thrust, and pipe spigots are witness marked short of full insertion to avoid such loads. A compressive force will invoke an undesirable hoop tensile stress at the root of the socket, and a

consequent reduction in operating safety factor.

Fig 4: Lengths of pipe required to support thrust from a blank end, per MPa of internal pressure. Source EBAA^{8††}

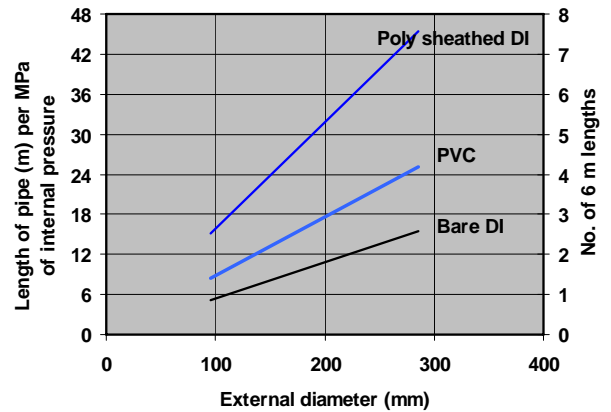

• **Services:**

Any axial movement of the downstream pipe will introduce a shear load on service connections that may rupture service lines or create leakage at tapping bands.

• **Safety:**

Operations or maintenance activities downstream of the closed valve, even a considerable distance, may disrupt the thrust support. WSA 03 points out:

“Although very few incidents of main / valve movement have been reported, there is the potential for a serious accident to occur in the event that a valve is dislodged under pressure during operation and maintenance activities e.g. a cut-in into the main adjacent to and downstream of the valve.”

Conclusion

Reliance on downstream pipes to support valves is fraught with risks and whilst the instance of problems may be small, it could not be considered best practice. What may have been considered an acceptable solution with bare iron pipes has changed radically with modern

⁸ The thrust developed at a blank end creates a tension force in the pipe when the joints are restrained by thrust restraint devices. The friction forces are the same in the case of a valve where compression is generated in the downstream pipes. A component of thrust support at the blank end is also included in the calculation, which is non-conservative since this does not exist in the case of a valve. The computation includes a factor of safety of 1.5.

^{††} DI pipes are normally 5.5 m lengths. The sockets offer a very small resistance to axial movement compared to the frictional resistance and the number of sockets does not materially affect the result.

materials and methods. It is strongly recommended that agencies adopt the common specification for independent thrust support, and remove the elements of doubt and risk.

References

- ¹ Comité Europé de Normalisation, ENV 1452-6:2002 "Plastics piping systems for water supply Unplasticized poly(vinyl chloride) (PVC-U) Part 6: Guidance for installation"
- ² American Water Works Association, ANSI/AWWA C605-94 "Underground Installation of Polyvinyl Chloride (PVC) Pressure Pipe and Fittings for Water"
- ³ International Organization for Standardization, ISO TR 4191 – 1989 "Unplasticized polyvinyl chloride

(PVC-U) pipes for water supply - recommended practice for laying"

⁴ Standards Australia, AS 2032-1977 "Installation of UPVC pipe systems"

⁵ Standards Australia, AS NZS 2566-1 1998 – "Buried flexible pipelines Part 1-Structural design"

⁶ Water Services Association of Australia, "Water Supply Code of Australia", 2002

⁷ Water Services Association of Australia, WSAA TN4 "Information and Guidance Note – Guidelines for design of pressure pipeline systems for water supply using PVC-M and PVC-O pipes"

⁸ EBAA Iron Inc, TX, USA, Computer program, "Restrained length calculation program", V5.02 2005

For further information about our products and applications, see our web site at

www.vinidex.com.au

Correspondence regarding this Technical Note should quote the reference number and version and be directed to:

The Technical Manager
Vinidex Pty Limited
Technical Services Group
254 Woodpark Rd.
Smithfield, NSW, 2164, Australia

Technical notes published by Vinidex represent the most advanced technology drawn from world wide research and field experience available to us at the time of printing. They are published in the interest of better understanding of the technicalities of our products and more satisfactory performance for users.

The application of such technology may involve engineering judgements which cannot be correctly made without intimate knowledge of all conditions pertaining to a specific installation. Technology may be superseded in the light of new laboratory and field work or changes to product specifications, and this Technical note may be withdrawn or amended without notice.

Responsibility lies solely with the User to ensure the currency and validity of information or advice contained herein in the context of his circumstances. It is recommended that advice be obtained from a Consultant registered with the Institution of Engineers Australia.

No warranty (other than Statutory Warranty) is expressed or implied as to the content of the information or results obtained by use thereof, and Vinidex Pty. Limited will not be held liable for any costs, direct or indirect, that may arise therefrom.