

Akasison XL Siphonic Roof Drainage

akasison

Specification manual





We are Aliaxis

As a pipe and fittings systems manufacturer, we exist to bring solutions to the world's water challenges and accelerate the transition to clean energy.

Water is central to who we are.

We are building on strong foundations and trust our teams to preserve this precious resource and enable access to clean water. We are also providing sanitation when millions and millions of people still do not have access to it.



Practical by principle

With Akasison, we have the practical solution in roof drainage. A special name, and one presented with pride. It stands for a group of specialists that always strive for better. Faster, smarter, safer. For Aliaxis it is always about the best system and solution.

We are very principled but not rigid. Because we are present on the roof, we are fully aware that a building is not designed to fit the roof drainage system, but the other way around. Rainwater drainage is only part of a larger context in which our system has to function. Which is why we like to work together.

It is about drainage based on tried and tested systems, and to never just follow the common herd. It is about craftsmanship, taking responsibility and providing top quality products and projects. Searching for innovation based on many years of experience. Improving systems and avoiding mistakes. The most valuable combination that a customer could wish for. There is nothing left to chance.



Information and safety recommendations

Validity

This Akasison XL specification manual 2026 is valid from January 2026. With the release of this edition all previous specification manuals are no longer valid. The latest valid technical information can be downloaded from www.akasison.com.

This document is protected by copyright. The resulting rights, in particular those of translation, reprinting, reuse of illustrations, the radio broadcasting, reproduction by photo-mechanical or similar means, and storage in data processing systems, are reserved.

This Specification Manual is produced with extreme care. All measurements and weights are approximate and errors and changes are reserved. Aliaxis Nederland B.V. does not accept any liability for damage caused by omitted or incorrectly referenced data in this manual.

Important information and pictograms

This manual contains pictograms to emphasize important or beneficial information:

 Important information to take into account.

 Consult Akasison Sales or Customer Service.

 Benefit.

 Additional information.

Safety and operating instructions

- Read the safety and operating instructions for your own safety and the safety of others carefully and completely before start of installation.
- Store the operating instructions and keep them available.
- If the safety instructions or operating instructions are unclear, please contact the Aliaxis Nederland Sales Office.

General precautions

- Keep your work area clean and free of obstructing objects.
- Provide adequate lighting of your work area.
- Keep unauthorized persons away of tools and the work area, especially at renovations in inhabited area.
- Use only Aliaxis Nederland and Akasison system components.

During assembly

- Always read and follow the operating instructions of the respective used tool.
- Improper use of tools can cause severe cuts, cause bruising or dismemberment.
- Improper use of tools can damage components and cause leaks
- Pipe cutters have a sharp blade. Store and handle without risk of injury.
- Note, when cutting the pipes, the safety distance between holding hand and cutting tool.
- Never grip the cutting zone of the tool or moving parts during the cutting process.

Recycling

HDPE pipes and fittings are 100% recyclable. Left over materials should be recycled as follows:

- Remainder pipe: residual waste
- Remainder fittings: residual waste
- Cleaning cloths: residual waste
- Wooden crating: recycled wood
- Carton boxes: recycled paper

Table of contents

Information and safety recommendations	2
Table of contents	3
1. Applications and design guidelines	6
1.1 Siphonic roof drainage system explained	6
1.2 Reinforcement of the roof profiles	10
1.3 Vapour barrier/damp proof membrane	10
1.4 Fire prevention	10
1.5 Condensation	11
1.6 Mounting system	11
2. Material properties	12
3. Standards and quality	14
4. Installation instructions	15
4.1 Roof outlets bitumen	15
4.2 Roof outlets PVC	16
4.3 Roof outlets FPO/TPO - PP	17
4.4 Roof outlets FPO/TPO - PE	18
4.5 Roof outlets clamp flange	19
4.6 Installation sockets	20
4.7 Reinforcement plates	21
4.8 Air baffles	22
4.9 Gutter outlets	23

Table of contents

5. Mounting system	25
5.1 Akasison fixing system	25
5.2 Overview of Akasison fixing system	26
5.3 Requirements for the installation of horizontal anchor points and horizontal guide brackets	27
5.4 Requirements for the installation of vertical anchor points and guide vertical brackets	29
5.5 Attachment of the mounting system to the building construction	31
5.6 Attachment of the rail suspension bracket to the trapezoid roof profile	32
6. Pipe system	33
6.1 Connection to the roof outlet	33
6.2 Change of direction	33
6.3 Branches	33
7. Jointing methods	34
7.1 Joint methods	34
7.2 Butt-weld joint	35
7.3 Electrofusion joint	37
7.4 Rubber ring joints	41
8. Product range	42
8.1 Dimensions	42
8.2 Pipe	42
8.3 Electrofusion	42
8.4 Buttwelding and the k-dimension	42
8.5 Abbreviations	42
8.6 Handling and storage	43

Table of contents

9. Overview	44
Roof outlets and airbaffles	44
Gutter outlets and emergency sets	45
Roof technology	46
Roof outlets	46
Installation sockets	56
Reinforcement plates	57
Air baffles	60
Gutter outlets	64
Emergency overflows	67
Fixing technology	68
Rails ⁶	68
Brackets	69
Pipes	72
Fittings	73
Reducers	73
Elbows	75
Branches	77
Connecting fittings	79
Electrofusion couplers	79
Expansions sockets	80
Tools	81
Electrofusion control boxes	81
Scrapers	83
Butt-welding machines	85
Accessories and spare parts	86
Appendices	86
Appendix A – Welding parametes	90
Appendix B – Commisioning	91
Alfabetical product index	92
Index of article numbers	94

1 Applications and design guidelines

1.1 Siphonic roof drainage system explained

The Akasison system for siphonic roof drainage considerably expands the possibilities for buildings with large and complex roofs. To respond, whether a consultant or installer, to the challenges faced by your clients and end users the Akasison system offers the following benefits:

- Save space for the function and mechanical services of the building
- Total freedom & flexibility of roof drainage design
- Economical installation with a light, plastic (HDPE) and welded pipe system
- Full peace of mind from a sophisticated risk management system

Siphonic roof drainage

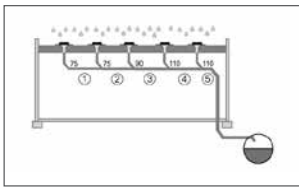

- Fewer down pipes
- Level pipe work
- Smaller diameters
- Less groundwork in building structure
- Use of full discharge capacity
- Self-cleaning pipes

Conventional roof drainage

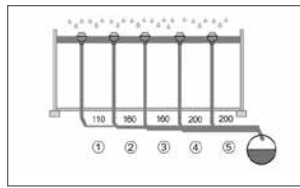

- Many down pipes
- Gradient pipe work
- Larger diameters
- Groundwork in building structure
- Reduced drainage capacity due to combination of water and air

The Akasison siphonic roof drainage system is engineered on the concept of full bore (a fill rate of 100%). This implies that rainwater flows at high speed through small diameter pipe work, at normally zero gradient. This siphonic effect is created by the (kinetic) energy derived from the hydraulic head, caused by the difference in height between the roof outlet and the discharge point in a building. Specialised roof outlets prevent air from being sucked into the system. The engineering principle of siphonic roof drainage design is based on the Bernoulli energy equation for a steady flow of an incompressible fluid with constant density. In order to balance the equation, and to guarantee the required siphonic effect according to the rainfall's intensity, the ideal pipe dimensions per flow path need to be determined.

$$\rho_1 + h_1 \rho g + \frac{1}{2} \rho V_1^2 = \rho_2 + h_2 \rho g + \frac{1}{2} \rho V_2^2$$

Equation 1.1

1.1.1 Basic principles

The capacity of siphonic roof drainage systems is calculated according to national standards and guidelines. The basic principles of a siphonic system are:

- Rain intensity for a primary system is measured in l/s/ha according to national legislation. For Dutch legislation, for example, this intensity relates to the rain intensity that occurs on average twice a year.
- Rain intensity for emergency overflow systems also need to be installed to conform to national legislation. According to national legislation, either the emergency system, or the combination of the standard and the emergency system, must be able to fulfil that capacity.
- Collectors should be installed without any incline.
- For optimum performance, the collector pipe should be installed between 0,8 m and 1,0 m below the roof.
- Different roofs can be connected to one siphonic roof drainage system if the height difference of the roof surface is less than one metre.
- Roof sections with equal runoff coefficients can be combined on a single system. Roof sections with different runoff coefficients cannot be combined. Additionally, both roof sections must receive water simultaneously; if one of the roof sections is subject to rain shadow and does not receive water at the same time as the other, the roof sections must not be combined.
- Large roof surfaces (approximately 5.000 m²) must be connected to at least two independent down pipes.

1.1.2 Design

The total volume of rainwater that has to be evacuated by the system can be calculated using equation 1.2.

$$V = i \cdot \alpha \cdot \beta \cdot A / 10.000$$

Equation 1.2

- V = total drainage volume (l/s)
- i = rain intensity (l/s/ha)
- α = reduction factor roof type
- β = reduction factor effective roof surface with roof under an angle
- A = effective roof surface (m²)

Having calculated the total volume of rainwater that has to be drained, the number of roof outlets can be calculated using equation 1.3.

$$N_{DT} = V / V_{DT}$$

Equation 1.3

- N_{DT} = number of roof outlets
- V = total drainage volume
- V_{DT} = drainage capacity of one roof outlet (l/s)

To determine the number of roof outlets, the structural details of the building like fire walls, roof construction and other (small) roofs that drain their rainwater onto the calculated roof surface must be taken into account. A roof outlet has to be placed on each lowest point of the roof construction. The maximum distance between two outlets is 20 m. The correct roof outlet can be chosen from the product range depending on roof construction, roof membrane, and the need for a heating element.

1.1.3 Calculation principles

A roof from which rainwater is drained by means of a siphonic system generally contains several roof outlets that are collected into a single downpipe. The Bernoulli equation needs to be applied to every flow path from roof outlet (entry point) to the transition to partial filling (exit point).

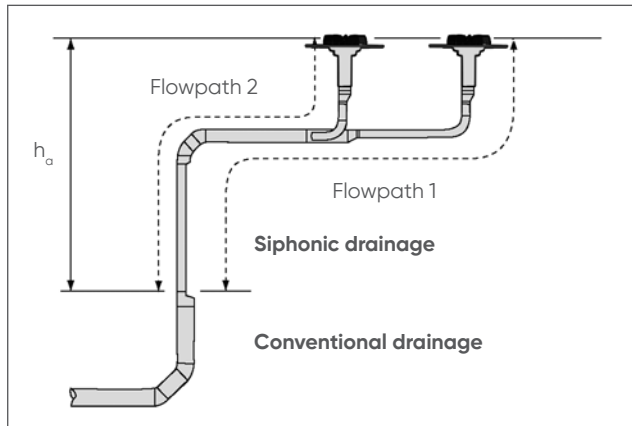

Illustration 1.1

The purpose of the calculation is to design a balanced system. The residual pressure at the exit point of each flow path should be either within ± 100 mBar or have a maximum difference of 100 mBar between flow paths, depending on the final project requirements.

The static residual pressure of a flow path is equal to the available pressure difference created by the height difference between the entry point and the exit point (h_a in equation 1.5) minus the pressure loss caused by the pipe friction in the auxiliary sections of the system.

$$\Delta p_{\text{rest}} = \Delta p_{\text{available}} - \Delta p_{\text{loss}}$$

Equation 1.4

The available pressure difference is calculated as indicated in equation 1.5.

$$\Delta p_{\text{available}} = \Delta h_a \cdot g \cdot \rho$$

Equation 1.5

Δh_a = available height from roof membrane to exit point

ρ = mass density of water at 10°C: 1.000 kg/m³

g = gravitational acceleration: 981 (m/s²)

Pressure loss is calculated as specified in equation 1.6.

$$\Delta p_{\text{loss}} = \Sigma (I \cdot R + Z)$$

Equation 1.6

I = pipe length (m)

R = pipe friction pressure loss (Pa/m) = $(\lambda/d) (0,5 \cdot v^2 \times r)$ with:

λ = pipe friction factor according to Pradtl-Colebrook (wall roughness $k_b = 0,25$ mm)

d_i = pipe section design diameter (m)

v = flow velocity in flow path (m/s) = Q_p/d_i

ρ = mass density of water at 10°C: 1.000 kg/m³

Q_p = rainwater load for the total roof section drained by the pipe

Z = minor losses of fittings (pa)

1.1.4 Calculations

The calculation of the various flow paths must begin with the most unfavourable flow path (insofar as pipe friction is concerned). In most cases, this flow path is from the roof outlet furthest removed from the exit point. To properly calculate the pressure difference and pressure loss for every flow path, and to test it against the 100 mbar standard, every flow path is divided into pipe sections (PS), see illustration 1.2. The pressure loss calculations for each individual section are summed up (Σ in equation 1.6) and subtracted from the summed up pressure differences for each pipe section. The pipe section runs from fitting (change of direction or diameter) to fitting, with the roof outlet being a separate pipe section (RO).

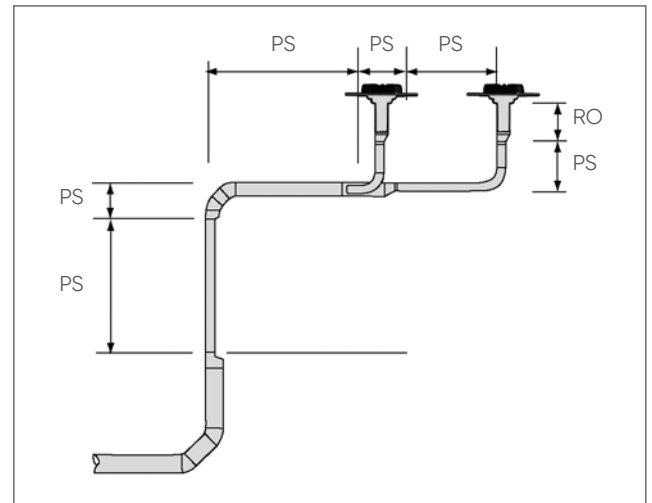

Illustration 1.2

Calculating the pressure difference of a pipe section

The available pressure difference of a pipe section is computed by replacing the Δh_a of equation 1.5 by the height difference of the pipe section.

$$\Delta p_{\text{available, ls}} = \Delta h_{\text{ls}} \cdot g \cdot \rho$$

Equation 1.7

Calculating the pressure loss of a pipe section

The pressure loss of a pipe section is calculated by using equation 1.6.

$$\Delta p_{\text{loss, ls}} = I \cdot R + Z$$

Equation 1.8

I = pipe length (m) = the length of the pipe section

R = pipe friction pressure loss (Pa/m) = $(\lambda/d) (0,5 \cdot v^2 \times r)$ with:

λ = pipe friction factor according to Pradtl-Colebrook (wall roughness $k_b = 0,25$ mm)

d_i = pipe section design diameter (m)

v = flow velocity in flow path (m/s) = Q_p/d_i

ρ = mass density of water at 10°C: 1.000 kg/m³

Q_p = rainwater load for the total roof section drained by the pipe

Z = minor losses of fittings (pa)

The flow path design diameter (d) is the only variable in the entire calculation (with the exception of down pipe diameter) that can be modified if the 100 mbar standard cannot be met.

Pipe friction is calculated in equation 1.9.

$$Z = \sum \zeta \cdot (0,5 \cdot v^2 \cdot \rho)$$

Equation 1.9

ζ = pipe friction of fitting

v = flow velocity in flow path (m/s)

ρ = mass density of water at 10°C: 1.000 kg/m³

Minor losses of fittings can be calculated via equation 1.9.

In contrast to a standard reduction, the exit point (transition to partial filling) has a larger friction factor. This point can be incorporated in the downpipe but also in the underground pipe (horizontal).

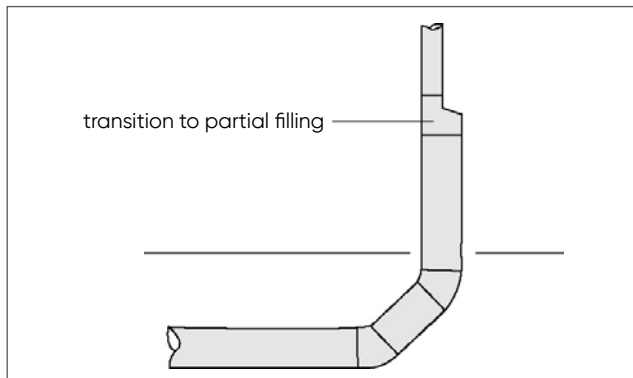

Illustration 1.3

The residual pressure is then determined by accumulating and offsetting the pressure differences and pressure losses of every pipe section.

$$\Delta p_{\text{rest}} = \sum \Delta p_{\text{available}} - \sum \Delta p_{\text{loss}}$$

Equation 1.10

If the result of the residual pressure does not remain under the stated standard of ± 100 mbar, the design diameters of one or more pipe section must be adjusted and retested.

1.1.5 System requirements

This paragraph provides details about the most important factor affecting the performance of a siphonic system: the static residual pressure of ± 100 mbar at the exit point. In addition, there are a few other requirements relating to pipe strength, self-cleaning, flow velocity and the design diameter of the downpipe.

Static pressure

Due to pipe strength, the static pressure at any given point (x) in a flow path must remain within the below-stated limits:

40 - 160 mm (s12,5) : -800 mbar
 200 - 315 mm (s12,5) : -800 mbar
 200 - 315 mm (s16) : -450 mbar

In contrast to the exit point where the residual pressure only entails static pressure, the residual pressure at every other point (x) in the pipe system consists of static and dynamic pressure. The equation for residual pressure at point x is:

$$\Delta p_{\text{rest}, x} = \Delta p_{\text{static}} + \Delta p_{\text{dynamic}, x}$$

Equation 1.11

The dynamic pressure in the system is calculated using equation 1.12.

$$\Delta p_{\text{dynamic}, x} = 0,5 \cdot v_x^2 \cdot \rho$$

Equation 1.12

v_x = flow velocity at point x

The available pressure difference and the flow losses for point x must then also be calculated. Equation 1.12 can hence be re-written as equation 1.13.

$$\Delta p_{\text{static}, x} + \Delta p_{\text{dynamic}, x} = \Delta p_{\text{available}, x} - \Delta p_{\text{loss}, x}$$

Equation 1.13

The applicable equation for static pressure at point x can now be written as equation 1.14.

$$\Delta p_{\text{static}, x} = \Delta p_{\text{available}, x} - \Delta p_{\text{loss}, x} + \Delta p_{\text{dynamic}, x}$$

Equation 1.14

$\Delta p_{\text{available}, x} = \Delta h_x \cdot g \cdot \rho$ (available height difference between the entry point and point x)
 $\Delta p_{\text{loss}, x} = \sum (l \cdot R + Z)$ (summed losses until point x)

Self-cleaning and velocities

To ensure the self-cleaning effect, the velocity in the system must be higher than 0,7 m/s. The permitted maximum discharge velocity is limited only by the technical limitations of the non-siphonic system into which the water discharges and, if applicable, the maximum exit velocity prescribed in the standard.

Design diameter of the down pipe

The start up volume flow can be calculated via equation 1.15

$$Q_{\text{start}} = Q_h \cdot \sqrt{\frac{\Delta H_i}{\Delta H_a}}$$

Equation 1.15

Q_{start} = minimum drainage at the transition point from the collector pipe to the down pipe (l/s)

Q_h = total rainwater load connected to the down pipe (l/s)

ΔH_i = height difference between entry point and the midpoint of the collector pipe (m)

ΔH_a = height difference between entry point and exit point (m)

Subsequently determine the design guidelines for the downpipe according to EN 12056, in which $Q_{\text{start}} > 1,2 \cdot Q_{\text{min}}$ and the length of the down pipe must be at least 4 m.

1.1.5 Emergency overflow

According to the standards, every flat roof should be able to cope with the five minute rainfall with a return period of 100 years. A light construction (steel) roof should always have an emergency overflow system. With all other roofs it needs to be checked if an emergency overflow system is necessary. This depends on the construction and shape of the roof and the expected rainfall. The emergency overflow should be able to drain the amount of rainfall exceeding the amount on which the standard system was calculated, or even the maximum 100 year storm. This differs per country, and sometimes by region.

An emergency overflow system can be constructed in a number of ways:

- Spouts through the roof edge
- Traditional gravitational system
- Siphonic roof drainage system

In a standard situation, an emergency overflow is a rectangular or round opening. This is the most economical solution, but not always possible or desired. In many projects it is necessary to drain the extra rainfall with emergency overflow roof outlets which are placed higher than the roof surface.

In the case of a siphonic emergency overflow system, the location of the emergency overflow roof outlets is important to prevent the intake of air. The location must be determined in collaboration between the builder and the designer of the emergency overflow system. In addition, the roof outlets and the connected pipes of the emergency overflow system can be divided into smaller drainage areas, with each collector having a separate outlet. The emergency overflow system must not be connected to the sewer. The individual emergency overflow roof outlets should be no more than 30 m apart.

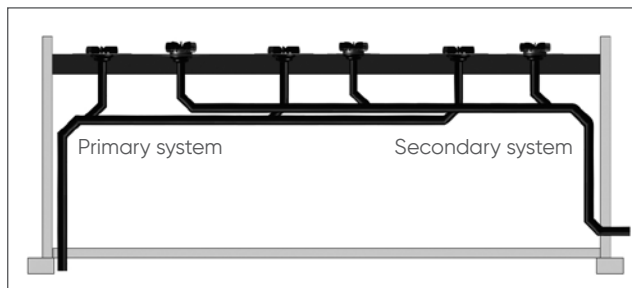

Illustration 1.4: Siphonic roof drainage system with siphonic emergency overflow (not connected to sewer)

Emergency overflow elements

Akasison provides a range of attachments designed to create reliable emergency overflow facilities. While a standard air baffle can serve this purpose, achieving the required roof elevation typically involves adding extra insulation—a method that is both time-consuming and prone to errors. To address this, Akasison has developed specialized elements that are quick and easy to install:

Emergency overflows with adjustable height

These allow precise adjustment to the level at which the primary system reaches its maximum capacity. If additional roof load occurs—such as from solar panel installation afterwards—the height can be easily modified. This flexibility reduces the maximum water level and, consequently, the roof load, ensuring a safe and efficient design.

Emergency overflow with Airlock technology

This innovative solution offers all the benefits above, plus unique features. The Airlock ensures that connected emergency overflows operate simultaneously, even if one funnel is not yet submerged. Additionally, this design further lowers the overall water level, reducing roof loads and solving issues where minimizing water accumulation is critical.



Illustration 1.5 Examples of Emergency outlets

1.2 Reinforcement of the roof profiles

The holes required for the roof outlets impair the strength of the trapezoidal roof profiles. According to local legislation these impairments may need to be (partly) compensated.

The reinforcement plate compensates for the impairment of the trapezoidal roof profiles. The plate is 660x660 mm, and 1,5 mm thick. The plate needs to cover at least two full sections of the trapezium profile at each side of the roof outlet. This specific plate is approved for Salzgitter types PS35, PS40, PS40S, PS85, PS100, PS135, PS153 and PS158 with a maximum thickness of 1,0 mm.

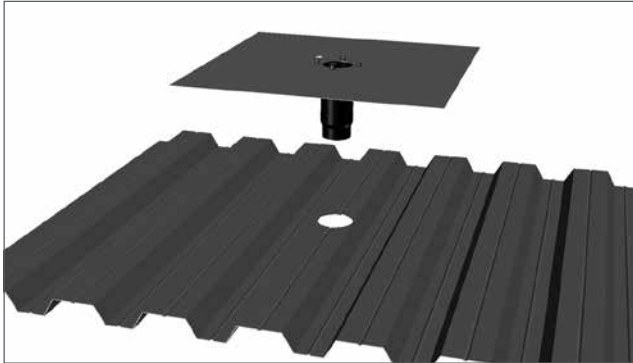

Illustration 1.6

The reinforcement plate also has the advantage that the pipe and mounting system can be installed independently from the installation of the outlets.

1.3 Vapour barrier/damp proof membrane

The vapour barrier prevents moisture from penetrating roof insulation and protects from a loss of thermal insulation value. The vapour barrier is usually a foil layer below the thermal insulation. The holes required for the roof outlets will usually perforate this vapour barrier, which can lead to local moist accumulation. However, the damp proof membrane can be sealed to the Akasion reinforcement plate, providing a simple solution for any type of damp proof membrane.

Installation socket

The 75 mm (200x200 mm) or 90 mm (220x220 mm) installation socket has the advantage of independent installation. The vapour layer can also be sealed to the installation socket. This product is used as an alternative for situations where reinforcement is not required.

Key advantages reinforcement plate and installation sockets

- Ease of planning: the system simplifies layout and installation under the roof, enabling faster and more efficient work.
- Maintenance-friendly: when the roof membrane needs replacement, the outlet can be removed from the socket without cutting any pipes, reducing labor and risk of damage. Cutting pipes in an active warehouse or factory during membrane replacement can be extremely difficult and costly—this design eliminates that challenge.
- Structural protection: the reinforcement plate absorbs tension and movement of roof outlets caused by drainage system extensions (e.g., due to temperature fluctuations). This prevents the outlet from damaging the roof surface and ensures long-term durability.



Illustration 1.7 installation socket

1.4 Fire prevention

Fire prevention measures are designed to reduce the risk of fire. They also ensure that if a fire does occur, its spread is delayed long enough to allow the occupants of a building to escape safely. The necessary measures will vary according to local requirements and legislation often differs by region and country. These requirements may relate to the time a building needs to be protected against collapse, the ability of fire barriers, and requirements related to the flammability of materials used.

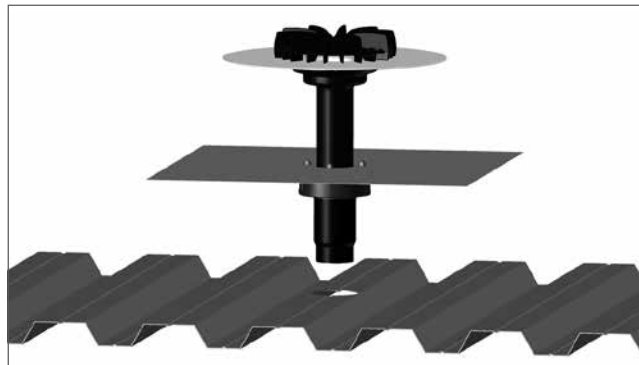

Illustration 1.8



Illustration 1.9

In case of fire this sleeve closes the roof outlet completely to prevent any chimney effect taking place and to prevent the fire from skipping to the insulation or roof surface .

The Akasion fireproof version is tested in accordance with DIN 18234/IndBauRL by the Research Centre for Fire Protection at the Karlsruhe Institute of Technology.

To ensure good fire protection, it is important to fill the cavities between reinforcement plates and trapezoidal profiles with fire resistant material.

1.5 Condensation

Condensation occurs when water vapour present in the air makes contact with a 'colder' surface. Air at a given temperature can contain only a certain amount of water vapour. If the air temperature drops when it comes into contact with a colder pipe system, the excess water vapour will condense. The temperature of the air at which it becomes saturated with water vapour is called the 'dew point'. Condensation occurs when pipework has a temperature under the dew point of the surrounding air. Condensation depends on a number of factors:

- Room temperature
- Relative humidity of the air
- Temperature of the pipe surface

Akasison rain drainage has a relatively good thermal coefficient. Experience shows that HDPE used in heated buildings (with an inside temperature of around 17°C) no condensation should occur during a short storm.

To determine exactly when and how to insulate, an h-x (Mollier) diagram should be used and a detailed calculation performed. The type and function of the building determines whether condensation can be permitted.

When insulating the pipe system, diffusion-proof, closed cell insulation material should be used. Open cell insulation must have an impermeable outer layer. The entire pipe network must be insulated and an insulated pipe system must always be a closed circuit.

1.6 Mounting system

The Akasison mounting system is designed specifically for horizontal siphonic roof drainage pipe systems. It absorbs changes in length without transferring tension onto the roof construction. The brackets can be installed single-handedly using easy clip on mounting. This allows maximum freedom of movement high in the building.

Benefits of this fixing system:

- Larger spans possible
- Less mounting onto the roof construction
- Prefabrication on ground level possible
- Only simple tools needed
- Room to apply insulation

2 Material properties

Polyethylene (PE for short), is a semi crystalline thermoplastic and is a generic term for many variations of the polymer. The most common are:

- LDPE (density: 0,9 - 0,91 g/cm³)
- MDPE (density: 0,93 - 0,94 g/cm³)
- HDPE (density: 0,94 - 0,965 g/cm³)

Aliaxis Nederland uses High Density Polyethylene (HDPE) for its products. The mechanical characteristics (elasticity, and stiffness) are important for the production of our pipes and different fittings. HDPE has a high resistance to damage from acids, bases and aqueous salt solutions. HDPE also has good resistance against light ionised radiation without becoming radioactive itself. The properties and benefits of Akatherm HDPE are highlighted in table 2.1 and 2.2.

Property	Unit	Test method	Value
Average linear expansion coefficient	mm/*K	DIN 53752	0,18
Operational temperature range without mechanical stress	°C	-	-40 to +80
Fire behaviour		DIN 4102	B2

Table 2.1

Material advantages

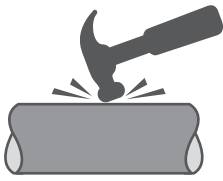

Impact-resistant and tough:
Unbreakable at temperatures above 5°C



Elastic and flexible:
Adjusts to local ground movement for underground use

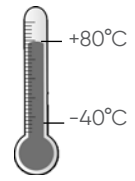

Thermal resistant:
Applications possible between -40°C and 80°C. Up to 100°C for short periods of time.



Chemical resistant:
Suitable for transport of polluted waste water

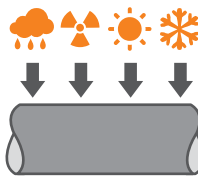

UV & weather resistant:
Unrestricted outside use through carbon black additives

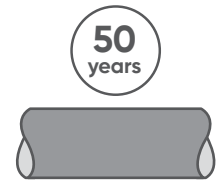

Wear resistant:
Lower cost due to long lifetime

System advantages

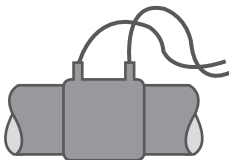

Welded system:
Simple and secure installation using butt welding and electrofusion



Homogeneous welded joints:
Pull tight and leak proof for a completely closed system

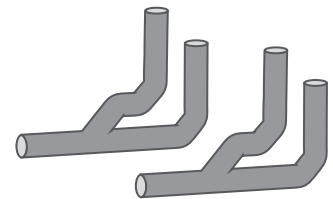

Prefabrication:
Fast and cost-saving installation of repetitive systems



Light in weight:
Cost saving in transport and handling



Low heat conductivity:
No condensation insulation required during short periods of cooling



Nontoxic:
100% recyclable and environmental friendly

Table 2.2

3 Standards and quality

Akasison stands for best quality products and services. To ensure we always meet the highest standards required we follow strict business practices which are externally audited. All certificates are also externally verified and validated.

We are fully ISO 9001 compliant and all our product development and manufacturing adheres to EN 1519 and other international and nationally approved standards.

The Akasison system has the appropriate national approval for most countries. These are all based on the international EN 1519.

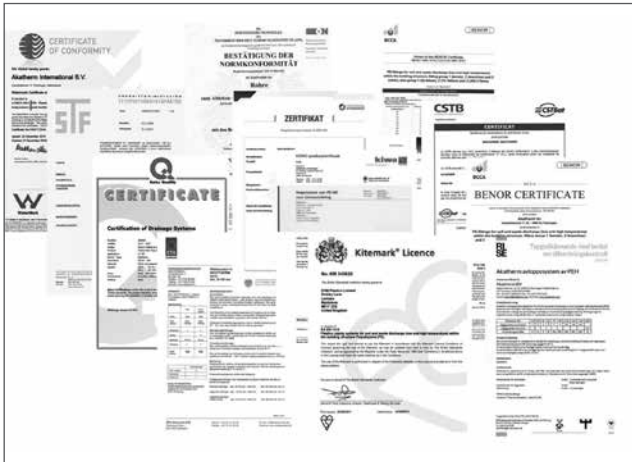

Image 3.1

ISO 9001

Aliaxis Nederland B.V., producer of Akasison, has a quality management system in full accordance with ISO 9001. It includes all business processes within Aliaxis Nederland B.V., ranging from development and production, to marketing and supply of plastic pipe systems. Conformity with ISO 9001 emphasises our quality, care and our continuous improvements in customer satisfaction. The certification of our management systems by Lloyd's Register Quality Assurance, further underscores Aliaxis Nederland B.V.'s standing as a leading brand of specialist drainage systems.



Image 3.2

ISO 14001

Aliaxis Nederland B.V., producer of Akasison, has integrated the ISO 14001 environmental management system into our quality management. ISO 14001 is a standard which controls and improves our overall environmental performance and focuses our attention on environmental factors during our everyday operations. It ensures that we make permanent environmental improvements and that we conform with all rules and regulations.



Image 3.3

Warranty

Above all, we provide our customers with peace of mind. We go to great lengths to ensure that our products perform as intended. The training we provide before installation begins; our technical support during construction, and inspection afterwards if required, allow us to guarantee the proper functioning of your Akasison system. All Aliaxis Nederland B.V. products have a 15 year warranty (details available on request).

4 Installation instructions

Scan the QR code or click on the hyperlink for the last updated installation instruction.

4.1 Roof outlets bitumen

Base roof outlet Akasison XL75 metal for bitumen

Code: 747342



Base roof outlet Akasison XL75 metal for bitumen (heated)

Code: 747343



Base roof outlet Akasison XL90 metal for bitumen

Code: 749342



Base roof outlet Akasison XL90 metal for bitumen (heated)

Code: 749343



Roof outlet Akasison XL75 metal for bitumen horizontal

Code: 747382



Roof outlet Akasison XL75 metal for bitumen horizontal (heated)

Code: 747383



4.2 Roof outlets PVC

Base roof outlet Akasion XL75 PVC

Code: 747544



Base roof outlet Akasion XL75 PVC (heated)

Code: 747545



Base roof outlet Akasion XL90 PVC

Code: 749044



Base roof outlet Akasion XL90 PVC (heated)

Code: 749045



Roof outlet Akasion XL75 PVC horizontal

Code: 747584



Roof outlet Akasion XL75 PVC horizontal (heated)

Code: 747585



4.3 Roof outlets FPO/TPO - PP

Base roof outlet Akasion XL75 FPO/TPO - PP

Code: 747546



Base roof outlet Akasion XL75 FPO/TPO - PP (heated)

Code: 747547



Base roof outlet Akasion XL90 FPO/TPO - PP

Code: 749046



Base roof outlet Akasion XL90 FPO/TPO - PP (heated)

Code: 749047



Roof outlet Akasion XL75 FPO/TPO - PP horizontal

Code: 747586



Roof outlet Akasion XL75 FPO/TPO - PP horizontal (heated)

Code: 747587



4.4 Roof outlets FPO/TPO - PE

Base roof outlet Akasion XL75 FPO/TPO - PE

Code: 747548



Base roof outlet Akasion XL75 FPO/TPO - PE (heated)

Code: 747549



Base roof outlet Akasion XL90 FPO/TPO - PE

Code: 749048



Base roof outlet Akasion XL90 FPO/TPO - PE (heated)

Code: 749049



Roof outlet Akasion XL75 FPO/TPO - PE horizontal

Code: 747588



Roof outlet Akasion XL75 FPO/TPO - PE horizontal (heated)

Code: 747589



4.5 Roof outlets clamp flange

Base roof outlet Akasion XL75 clamp flange

Code: 747540



Base roof outlet Akasion XL75 clamp flange (heated)

Code: 747541



Base roof outlet Akasion XL90 clamp flange

Code: 749040



Base roof outlet Akasion XL90 clamp flange (heated)

Code: 749041



Roof outlet Akasion XL75 HR clamp flange horizontal

Code: 747580



Roof outlet Akasion XL75 HR clamp flange horizontal (heated)

Code: 747581



4.6 Installation sockets

Akasion XL75 installation socket

Code: 747713



Akasion XL90 installation socket

Code: 749713



4.7 Reinforcement plates

Akasion XL75 reinforcement plate without connector

Code: 747712

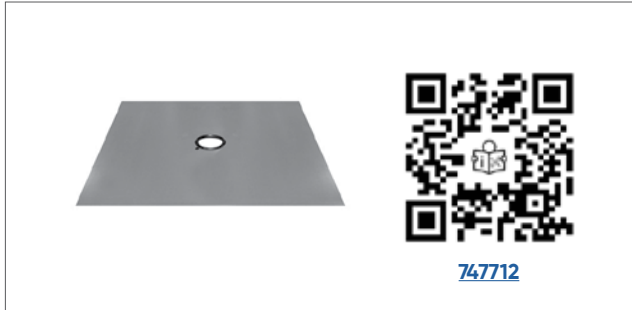

Akasion XL75 reinforcement plate with vapour barrier connection

Code: 747711



Akasion XL75 reinforcement plate with vapour barrier connection and fire protection

Code: 747723



Akasion XL90 reinforcement plate with vapour barrier connection

Code: 749711



Akasion XL90 reinforcement plate with vapour barrier connection and fire protection

Code: 749722



4.8 Air baffles

Air baffle with integrated leafguard 250

Code: 747550

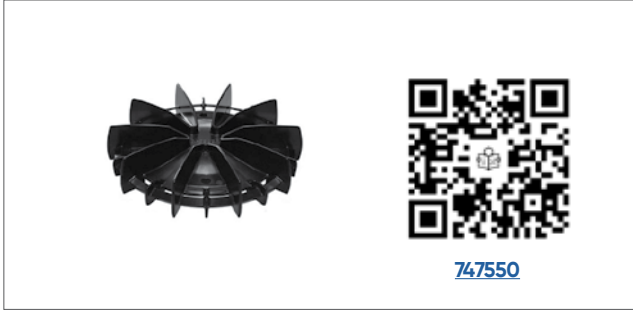

Air baffle with integrated leafguard 420

Code: 749053

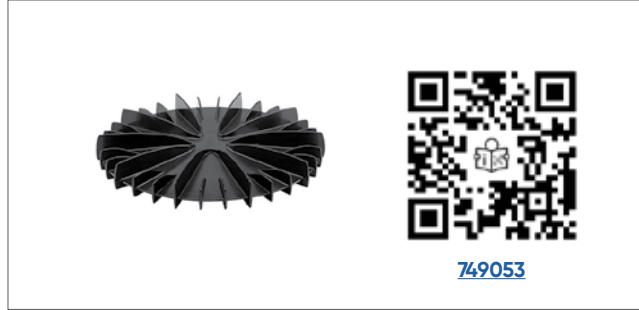

Air baffle with integrated leafguard height adjustable emergency overflow XL75

Code: 747551



Air baffle Airlock with integrated leafguard height adjustable emergency overflow XL75

Code: 747554



Air baffle with integrated leafguard emergency overflow

Code: 747552



4.9 Gutter outlets

Roof outlet Akasison XL75 for metal gutter

Code: 747800



Roof outlet Akasison XL75 for metal gutter covered

Code: 747802



Roof outlet Akasison XL75 with clamp flange for metal gutter

Code: 747808



Roof outlet Akasison XL90 for metal gutter

Code: 749800



Roof outlet Akasison XL90 with clamp flange for metal gutter

Code: 749808



Roof outlet Akasison XL75 for concrete gutter

Code: 747801



Roof outlet Akasion XL75 for concrete gutter covered

Code: 747803



Roof outlet Akasion XL90 for concrete gutter

Code: 749801



5 Mounting system

The Akasion XL system includes a unique fixing system. This system ensures the correct installation of the Akasion drainage system.

5.1 Akasion fixing system

The Akasion XL system has to be fixed to the roof construction using the Akasion fixing system. The fixing system is a rigid installation with anchor points that will absorb any expansion and contraction of the HDPE as a result of temperature changes. It protects the integrity of the HDPE installation.

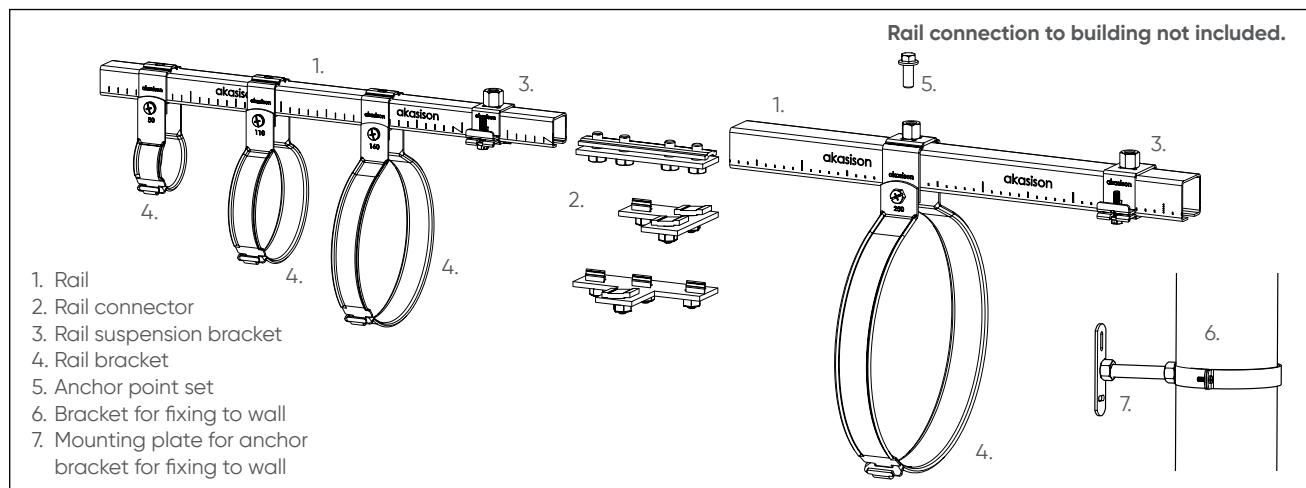

Illustration 5.1

Rail

Type	Code	Application
30x30 mm x 5 m	700005	Rail bracket 40-200 mm
41x41 mm x 5 m	700007	Rail bracket 250 and 315 mm

Table 5.1

Anchor point

Type	Code	Application
M10x20 (Set of 2)	730025	Anchorpoint for $d_1 = 200$ mm
M10x45 (Set of 2)	730027	Anchorpoint for $d_1 \geq 250$ mm

Table 5.5

Rail connector

Type	Code	Application
Rail connector straight	700015	Rail 30x30 and 41x41 mm
Rail connector L	700016	Rail 30x30 and 41x41 mm
Rail connector T	700017	Rail 30x30 and 41x41 mm

Table 5.2

Rail suspension bracket

Type	Code	Application
30x30 mm	700025	Rail 30x30 mm
41x41 mm	700027	Rail 41x41 mm

Table 5.3

Rail bracket

Type	Code
40 mm	750435
50 mm	750535
56 mm	755635
63 mm	750635
75 mm	750735
90 mm	750935
110 mm	751135
125 mm	751235
160 mm	751635
200 mm	752035
250 mm	752535
315 mm	753135

Table 5.4

Bracket for fixing to wall

Diameter	Code	Thread
40 mm	700478	1/2"
50 mm	700578	1/2"
56 mm	705678	1/2"
63 mm	700678	1/2"
70 mm	700778	1/2"
90 mm	700978	1/2"
110 mm	701178	1/2"
125 mm	701278	1/2"
160 mm	701678	1/2"
200 mm	702080	1"
250 mm	702580	1"
315 mm	703180	1"

Table 5.6

Mounting plate for 1/2" and 1" anchor bracket

Thread	Code
1/2"	709478
1"	709480

Table 5.7

5.2 Overview of Akasion fixing system

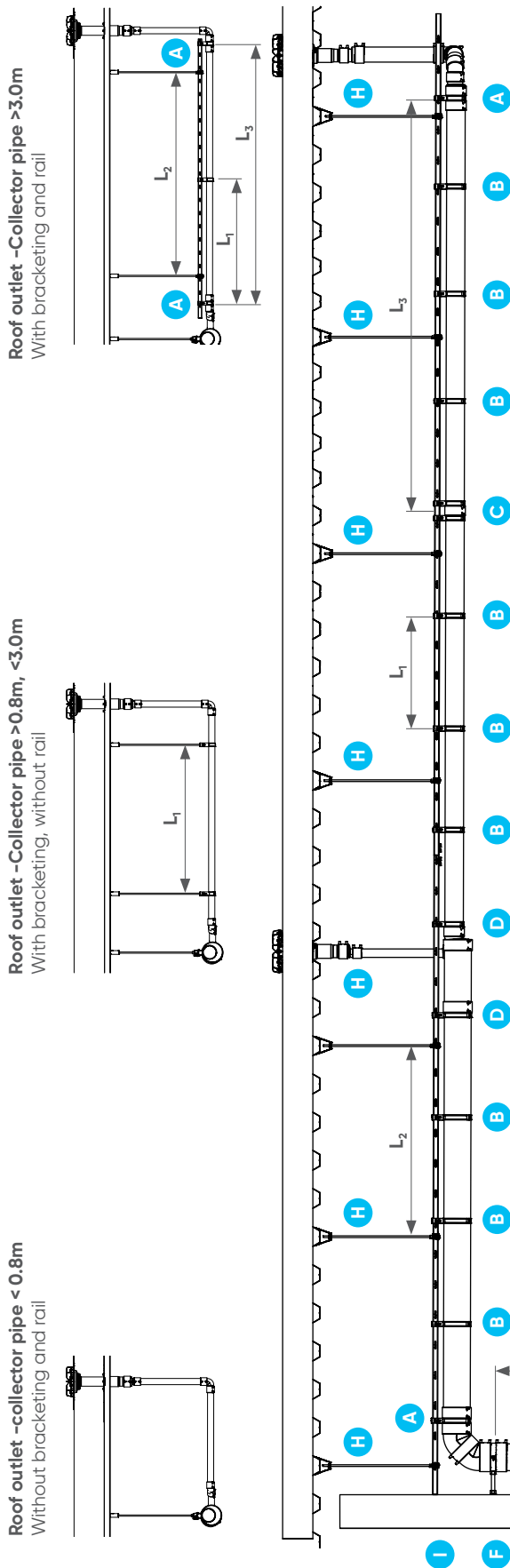

Diameter pipe d ₁ (mm)	Rail (mm)	Max. guide bracket distance Horizontal L ₁ (m)	Max. distance rail suspension L ₂ (m)	Max. anchor point distance L ₃ (m)	Guide bracket distance vertical L ₄ (m)
40	30 x 30	0,85	2,50	5,00	1,00
50	30 x 30	0,85	2,50	5,00	1,00
56	30 x 30	0,85	2,50	5,00	1,00
63	30 x 30	0,85	2,50	5,00	1,00
75	30 x 30	0,85	2,50	5,00	1,25
90	30 x 30	0,85	2,50	5,00	1,25
110	30 x 30	1,00	2,50	5,00	1,65
125	30 x 30	1,25	2,50	5,00	1,65
160	30 x 30	1,65	2,00	5,00	2,50
200	30 x 30	1,65	1,65	5,00	2,50
250	41 x 41	1,65	1,65	5,00	2,50
315	41 x 41	1,65	1,65	5,00	2,50

Table 5.8

- A** Anchor point at end of collector
- B** Guide bracket horizontal
- C** Anchor point horizontal
- D** Anchor point horizontal at y-branch
- E** Anchor point vertical
- F** Anchor point at end of stack
- G** Guide bracket vertical
- H** Rail suspension bracket
- I** Rail connection to building

Guide and anchor points bracket distance

The Akasion XL drainage system consists of guide brackets and anchor point brackets. Anchor points have to be placed at specific intervals to keep the drainage system in a fixed position. Guide brackets are placed in between anchor points locations to guide and support the pipe weight.

Anchor point bracket distances

- Anchor points must be installed in these locations:
- Every 5 m horizontal pipe
 - At the beginning and the end of the collector pipe
 - At every 45° branch
 - At every change of direction
 - At the beginning and end of the pipe from roof outlet to collector (>3m)

Guide brackets distance

The guide bracket distance depends on the diameter of the pipe. To increase the distance between each guide bracket, support trays can be used up to diameter 160 mm. The support trays are fixed in place using straps every 0.5 m.

Rail connection to the building

The rail itself must be fixed to the construction at specific intervals so the HDPE expansion and contraction are transferred to the building. This will prevent movement of the installation.

- The rail must be fixed to the building at:
- The beginning of each horizontal pipe section
 - Every 12 m of each horizontal pipe section
 - A horizontal direction change
 - A wall-interruption at both sides of the wall
 - A vertical direction change

5.3 Requirements for the installation of horizontal anchor points and horizontal guide brackets

5.3.1 Overview

The Akasion XL drainage system consists of guide brackets and anchor points brackets. Anchor points have to be placed at specific intervals to keep the drainage system in a fixed position. Guide brackets are placed in between anchor point locations to guide and support the pipe weight.

When installing an Akasion rail system, an anchor point needs to be applied:

- Every 5 metres of horizontal pipe section
- At the beginning and end of the collector
- At every 45° Y-branch
- At every bend and every change of direction
- At the beginning and end of the drain connection line > 3,0 m

Between anchor points, horizontal guide brackets need to be installed. The maximum distance between the brackets (guide-guide or guide-anchor point) are indicated as L_1 in the table of paragraph 5.2. A standard anchor point is installed with two rail brackets and an electrofusion coupler. The rail brackets are mounted on both sides of the electrofusion coupler. It is also possible to use two electrical couplers and one rail bracket. This is mainly used in combination with fittings. To prevent the brackets from sliding, the screws of the brackets need to be firmly tightened. Extra anchorpoint screws are also used for 200-315 mm brackets.

5.3.2 Examples of Anchor points and guide brackets

Anchor point in the horizontal collector

Diameter 40-160 mm

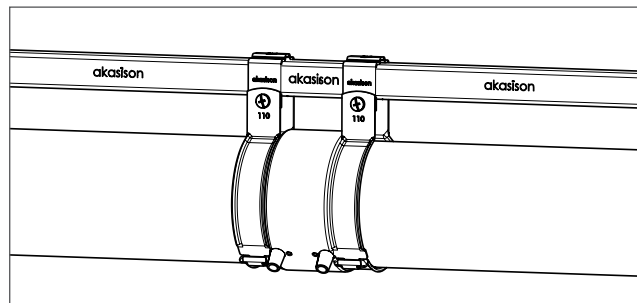

Illustration 5.2

- 1 x electrofusion coupler
- 2 x rail brackets

Diameter 200-315 mm

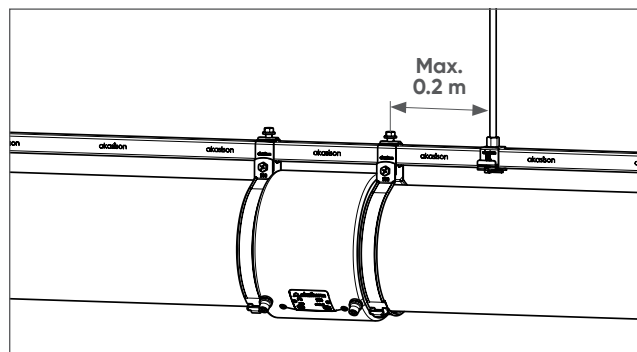

Illustration 5.3

- 1 x electrofusion coupler
- 2 x rail brackets
- 2 x anchor point sets

Anchor point at the beginning of the collector

Diameter 40-160 mm

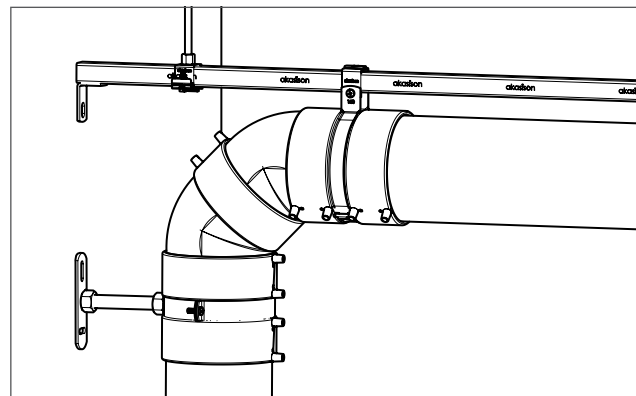

Illustration 5.4

- 2 x electrofusion couplers
- 1 x rail bracket

Diameter 200-315 mm

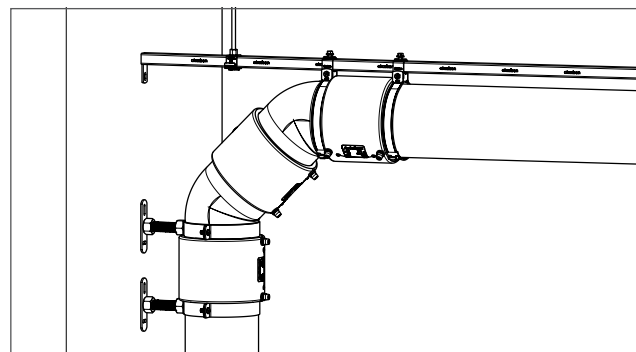

Illustration 5.5

- 1 x electrofusion coupler
- 2 x rail brackets
- 2 x anchor point sets

Anchor point at the end of the collector

Diameter 40-160 mm

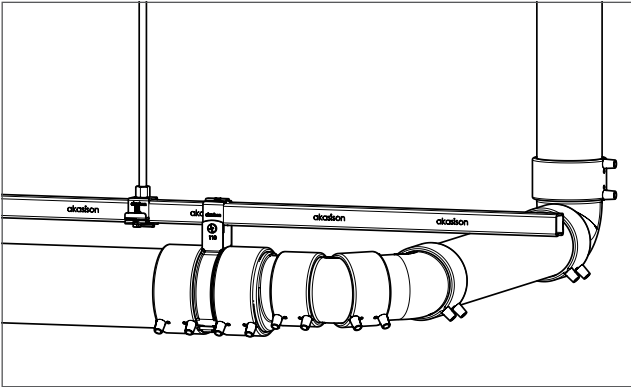

Illustration 5.6

- 2 x electrofusion couplers
- 1 x rail bracket

Anchor point 45° Y-branch

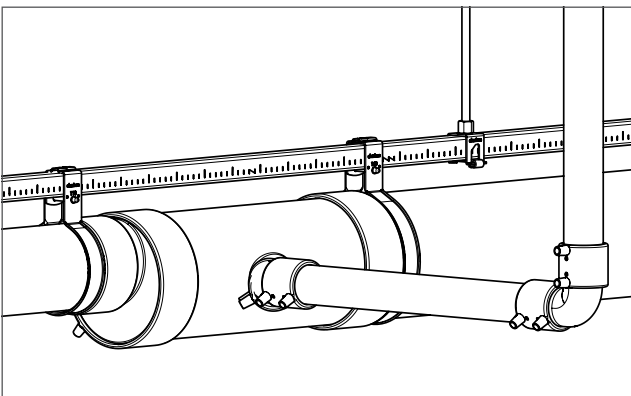

Illustration 5.7

- 2 x electrofusion couplers
- 2 x rail brackets

Anchor point by change of direction

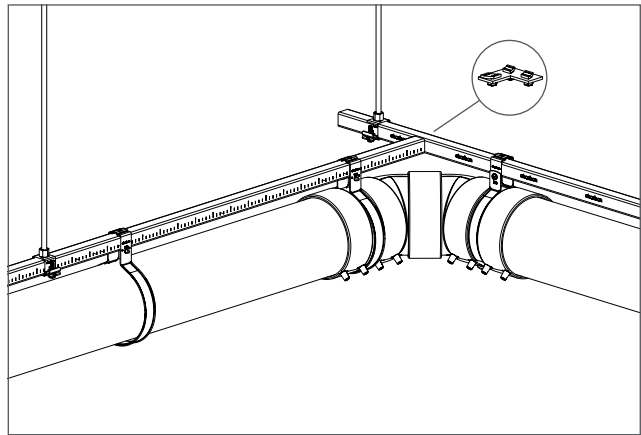

Illustration 5.8

- 2 x electrofusion couplers
- 1 x rail bracket

Guide bracket

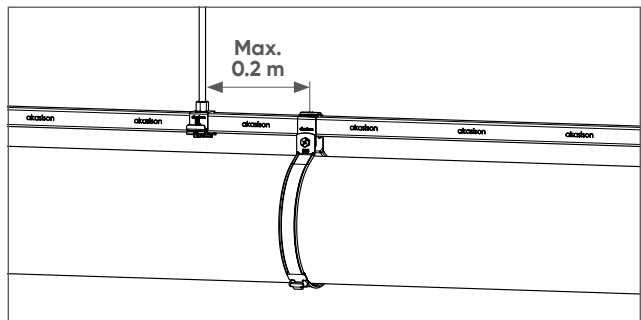

Illustration 5.9

- 1 x rail bracket

5.4 Requirements for the installation of vertical anchor points and vertical guide brackets

5.4.1 Overview

When installing an Akasion rail system, an anchor point needs to be applied:

- Every 5 metres in the vertical collector pipe
- At the beginning (top) of the vertical collector pipe

Between anchor points, vertical guide brackets need to be applied. The maximum distance between the brackets (guide-guide or guide-anchor point) are indicated as L4 in the table 5.8 of paragraph 5.2.

For the installation of the system to the wall, a mounting plate and a wall bracket is used. For diameters up to 160 mm 1/2" is used. For diameters above 200 mm 1" is used. The required threaded rod is not included. For an anchor point, an electrofusion coupler and an expansion socket are also used.

5.4.2 Examples of anchor points and guide brackets

Anchor point

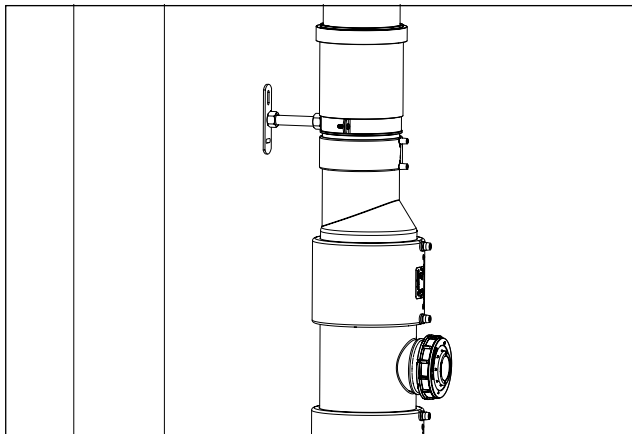

Illustration 5.10

- 1 x expansion socket
- 1 x electrofusion coupler
- 1 x rail bracket
- 1 x mounting plate

Anchor point at the beginning of the collector

Diameter 40-160 mm

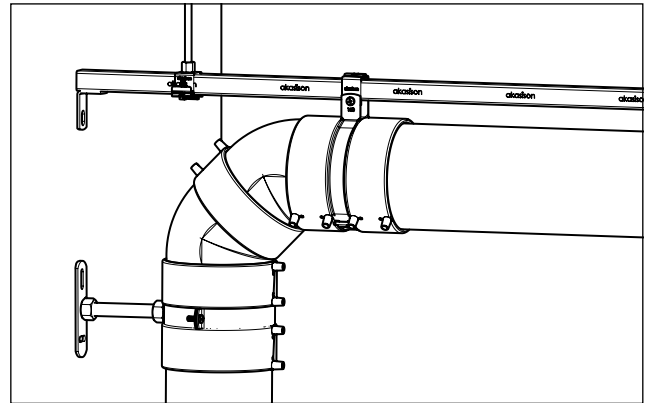

Illustration 5.11

- 2 x electrofusion couplers
- 1 x rail bracket
- 1 x mounting plate 1/2"

Diameter 200-315 mm

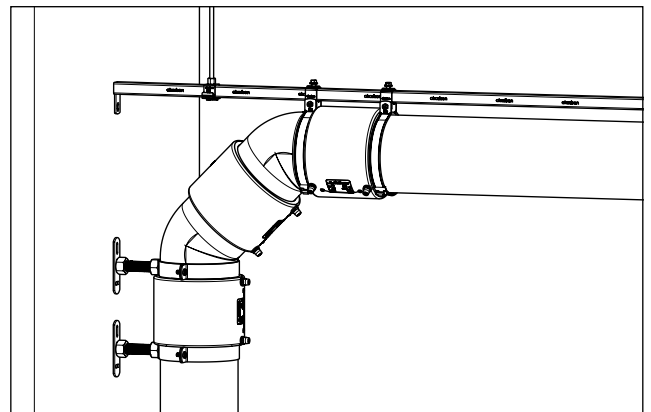

Illustration 5.12

- 1 x electrofusion coupler
- 2 x rail brackets
- 2 x mounting plates 1"

Anchor point at the beginning of the collector with reduction

Diameter reduction 200-300 mm

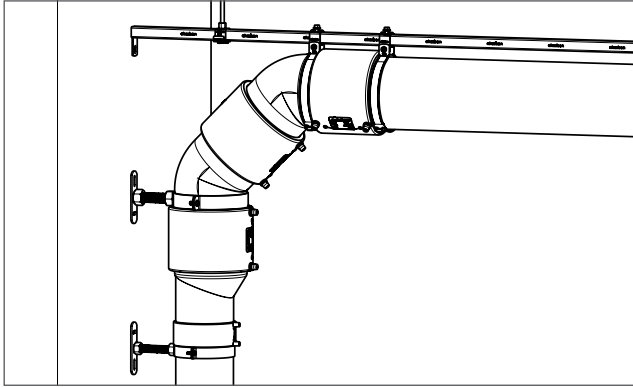

Illustration 5.13

- 2 x electrofusion couplers
- 2 x rail brackets
- 2 x mounting plates 1" (when diameter after reduction is > 160 mm)

or

- 2 x electrofusion couplers
- 2 x rail brackets
- 1 x mounting plate 1"
- 1 x mounting plate 1/2" (when diameter after reduction is ≤ 160 mm)

Diameter 40-160 mm

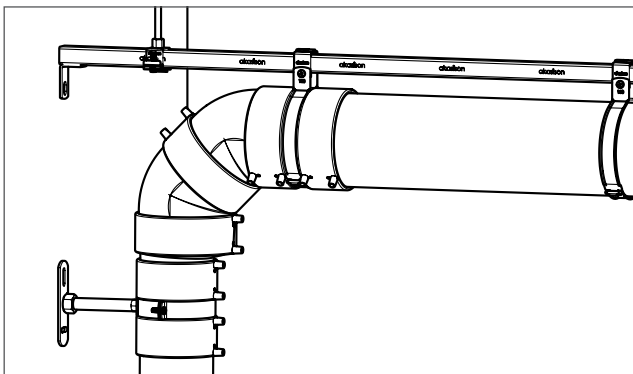

Illustration 5.14

- 2x electrofusion coupler
- 1 x rail bracket
- 2 x mounting plate 1/2"

Guide bracket

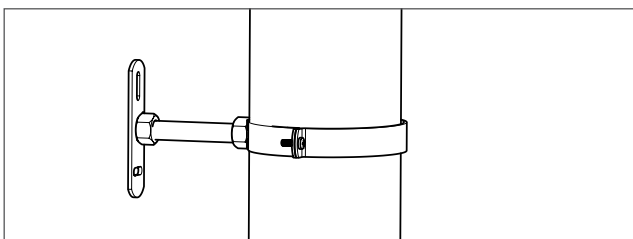

Illustration 5.15

- 1 x rail bracket
- 1 x mounting plate 1/2" (diameter ≤ 160) or 1 x mounting plate 1" (diameter > 160 mm)

5.4.3 Maximum distance between wall and drainage system

The threaded rods for the fixation of the mounting plate to the bracket is limited.

For a distance up to 100 mm of 40-160 mm pipe, a 1/2" bracket and mounting plate is needed. For 200-315 mm pipe, a 1" mounting plate and bracket is required.

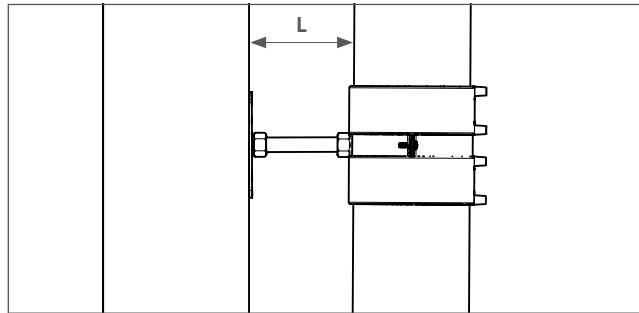

Illustration 5.16

5.5 Attachment of the mounting system to the building construction

5.5.1 Overview

Akasion rails need to be attached the building:

- at the start and end of a horizontal collector pipe
- at every 12 metres of the collector pipe
- at every transit of the wall, at both sides of the wall
- at every vertical change of direction

5.5.2 Examples the attachment of the system to the building

At the beginning of the horizontal collector pipe

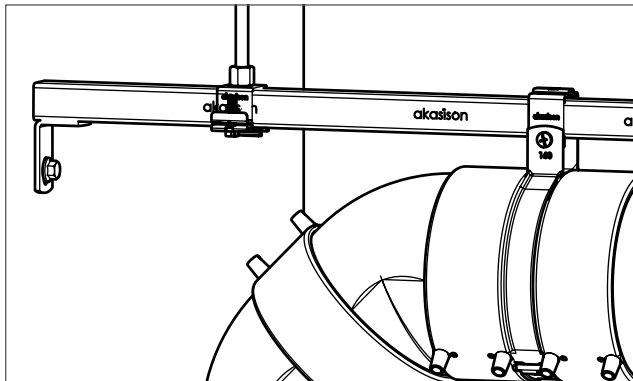

Illustration 5.17

Connection with a horizontal beam (both sides)

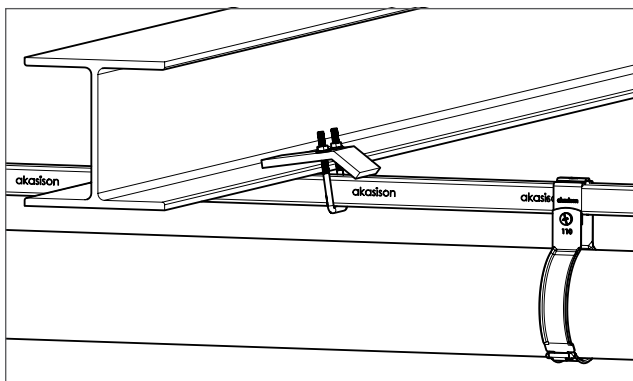

Illustration 5.18

Connection with a concrete beam (both sides)

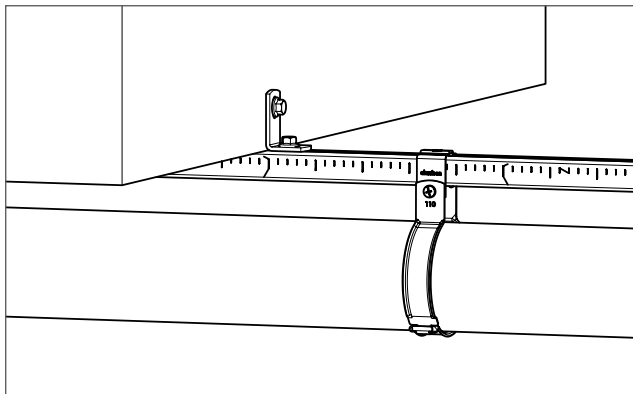

Illustration 5.19

Connection with the transit of a wall (both sides)

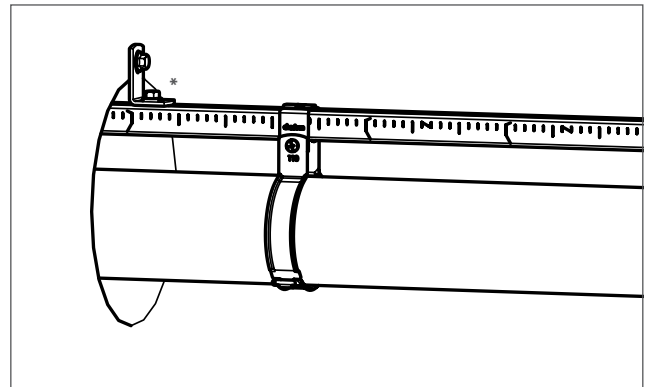

Illustration 5.20

* Rail can be used upside down.

5.6 Attachment of the rail suspension bracket to the trapezoid roof profile

5.6.1 Overview

The maximum distance of the rail suspension (as defined in the table f paragraph 5.2) must not be exceeded. The construction of the roof might limit this maximum distance. The impact on the construction of the drainage system needs to be approved by the constructor responsible before starting the installation the system.

In the table below the total weight and forces of the system are given, by the maximal distance of the suspension brackets.

Operational system (pipe, mounting system, totally filled with water)

d_1 [mm]	40	50	56	63	75	90	110	125	160	200	250	315
G [kg/m]	2,9	3,7	4,2	4,8	6,2	8,1	11,2	14,0	21,8	33,3	51,9	81,0
F [kg/T]	7,4	9,1	10,4	12,1	15,4	20,3	28,1	35,0	43,7	55,0	85,7	133,7

Table 5.8

Non-operational system (pipe, mounting system, no water)

d_1 [mm]	40	50	56	63	75	90	110	125	160	200	250	315
G [kg/m]	2,0	2,2	2,2	2,2	2,5	2,7	3,1	3,5	4,7	6,5	10,3	14,6
F [kg/T]	5,0	5,4	5,6	5,6	6,2	7,7	8,9	8,9	9,4	10,8	17,0	24,1

Table 5.9

G = weight of the system

F = resulting point load applying the maximum distance between the suspension brackets

In the table below maximum distances between the suspension brackets (L_2) are calculated based on a maximum point load.

d_1 [mm]	15 kg/m ² L_2 [m]	20 kg/m ² L_2 [m]	25 kg/m ² L_2 [m]	30 kg/m ² L_2 [m]	35 kg/m ² L_2 [m]	40 kg/m ² L_2 [m]	45 kg/m ² L_2 [m]	50 kg/m ² L_2 [m]
40	2,50	2,50	2,50	2,50	2,50	2,50	2,50	2,50
50	2,50	2,50	2,50	2,50	2,50	2,50	2,50	2,50
56	2,50	2,50	2,50	2,50	2,50	2,50	2,50	2,50
63	2,50	2,50	2,50	2,50	2,50	2,50	2,50	2,50
75	2,40	2,50	2,50	2,50	2,50	2,50	2,50	2,50
90	1,80	2,50	2,50	2,50	2,50	2,50	2,50	2,50
110	1,30	1,80	2,20	2,50	2,50	2,50	2,50	2,50
125	1,10	1,40	1,80	2,10	2,50	2,50	2,50	2,50
160	-	-	1,10	1,40	1,60	1,80	2,00	2,00
200	-	-	-	-	1,10	1,20	1,40	1,50
250	-	-	-	-	-	-	-	-
315	-	-	-	-	-	-	-	-

Table 5.10

Distances less than one metre, there is no standard connection possible. In that case a project solution needs to be derived. A possible solution is to divide the load, or mount the system to metal beams.

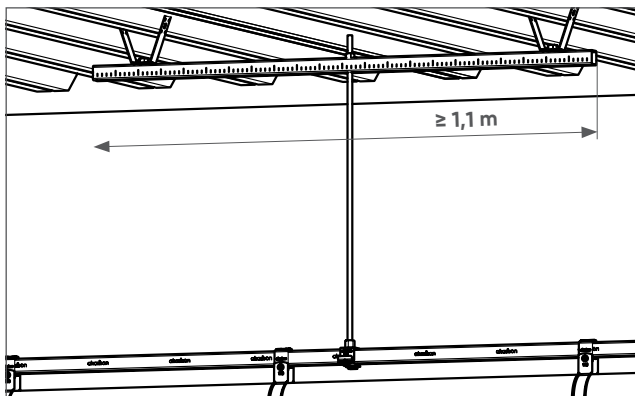

Illustration 5.21

6 Pipe system

6.1 Connection to the roof outlet

The connection of the roof outlet to the Akatherm PE pipe system depends on the roof outlet.

Roof outlet	Connection method	Art. Nr.
Ø75	Electrofusion coupler 75 mm	410795
Ø90	Electrofusion coupler 90 mm	410995

Table 6.1 Roof outlet connection to the pipe system

The isometric drawing will list the outlet and transition to the PE pipe as a separate pipe section (according to VDI 3608). The length of this pipe section is the height of the roof outlet. The parts list will separately specify the connection piece and the possible reduction to the diameter of the following pipe section.

The transition from the vertical to the horizontal pipe section under the roof outlet must be done under a 90° angle for optimal siphonic priming. A 90° bend can be used but requires a butt weld on one end. Use an 88.5° elbow for an installation that can be 100% electrofused.

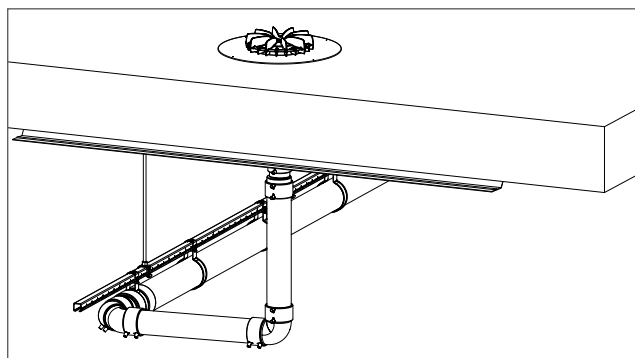

Illustration 6.1

6.2 Change of direction

Except for the transition underneath the roof outlet, the pipe system does not include any 90° bends. All changes of direction are made by using 45° elbows.

6.3 Branches

Only branches of 45° are used in the PE pipe system. For the connection to the main collector a 45° branch and a 45° elbow are combined to make the angle of 90°. At a horizontal or vertical branch the rules for direction changes and branches are combined.



Illustration 6.1

6.4 Reductions

It is not permitted to reduce the pipe diameter in the direction of flow, except in the vertical pipe section directly underneath the roof outlet, and in the downpipe. Only eccentric reducers are used. When a diameter change is needed directly underneath a roof outlet, a centric reducer can be used.

6.5 Emergency overflow

Every roof should be equipped with an emergency overflow system. This system operates when the primary system cannot deal with the rainwater. This can be the case when the amount of rain exceeds the rainfall on which the system was dimensioned, or by a blocked sewer. For the dimensioning and design of the emergency overflows, the local standards prevail. The system can be designed as a siphonic system, a traditional system, or with spouts in the facade of the roof. In this case the emergency system works as an early warning that something is amiss.

The emergency overflow system cannot be connected to the main sewer but has to exit freely.

6.6 Maintenance and cleaning when in use

It is important that the roof is kept clean in spite of the self-cleaning of the Akasison siphonic roof drainage system.

Items such as leaves and plants that are on the roof should be removed regularly to prevent blocking pipes and obstructing water flow. The frequency of inspection and cleaning depends largely on the surroundings of the building. A location with large trees in the vicinity will need a more frequent inspection than a location in an open field. When cleaning the roof outlet, the air baffle can be easily removed to clean the roof outlet on the inside.

For roof outlets equipped with heating elements: A roof covered with snow requires special attention. The heating elements in these outlets will only melt the snow inside the outlet itself, and the siphonic system will only drain the melted water. Because snow is a good insulator, even when temperatures rise above 0 °C, the bottom layer of snow may not melt, resulting in minimal drainage. Therefore, the outlets must be cleared of snow. If the snow load exceeds the maximum allowed on the roof, it must be removed.

7 Jointing methods

7.1 Joint methods

Akatherm HDPE is suitable for High Density Polyethylene, a material made with welded joints. Secure and durable connections lasting 50 to 100 years. Welded joints are made without the need for glue or rubber ring joints and are actually stronger than the surrounding piece of pipe or fitting. HDPE welded joints are both pull tight and leak proof, once tested there is very little risk of future failure because of the flexibility, impact resistance and overall toughness of the material.

Besides welded joints Akatherm HDPE pipes and fittings can be joined by different methods, depending on the applications. Joints are divided in welded/mechanical and pull-tight/not pull-tight. Pull tight joints can't come apart under influence of external forces.

To be opened (dismountable)

This are jointing methods which can be disconnected after assembly. These jointing methods are ideal for pipe sections which need to be cleaned, calibrated, inspected or dismantled on a regular basis.

Not to be opened (fixed)

This are jointing methods which cannot be disconnected after assembly. These are permanent joints in which the joints can remain closed for their lifetime.

Tension-resistant (pull tight: PT)

This are connections which withstand tensional forces. This is ideal when thermal movement is expected or gravity pulls on the connection.

Non-tension-resistant (not pull tight: NPT)

This are connections which cannot withstand tensional forces. This joint is used when the pipe system is designed to accommodate movement without risk that the joint is pulled apart.



Jointing technique	Product	Welded/mechanical	Pull-tight	Dismountable
Butt-weld joint		Welded	Yes	No
Electrofusion		Welded	Yes	No
Plug-in socket		Mechanical	No	Yes
Expansion socket		Mechanical	No	Yes

Table 71

7.2 Butt-weld joint

Butt-welding is an economical and reliable way of joining without using additional components requiring only butt-welding equipment.

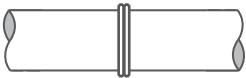
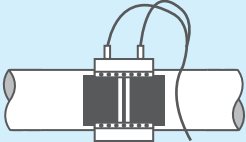
All Akatherm products can be welded using this joining method (DVS 2207-1). Fittings can be shortened by up to the k-dimension when indicated in the catalogue, still allowing butt-welding. This joining method is very suitable for prefabrication and producing special fittings.

Preparations

Before starting the welding process it is important to establish a work space where the joining can be done consistently:

- The temperature of the welding plate needs to be between 200°C and 220°C. In general it is advisable to consider welding with higher temperatures in this temperature range when welding pipes and fittings with small wall-thickness. Pipes and fittings with a relative higher surface area need to be heated more slowly
- Ensure that the welding plate has reached the correct temperature and is thoroughly heated. In order to do so allow for a 10 minute heating period after the correct temperature is measured initially
- Before welding clean the heating element with paper and a pre approved cleaning solution (Ensuring 100% evaporation). Ensure that the heating surface is undamaged
- Establish a work space where the joining can be done without being affected by major weather conditions. The use of wind shields is advised to keep the weld plate at a constant temperature
- The functionality of the butt welding equipment needs to be checked regularly. Especially on those machines which are used at the building site.

Welding process

In general butt-welds are made using an Akatherm butt-welding machine. Only diameters up to 75 mm can be welded by hand. For diameters at 90 mm and above the welding pressure is too big to make a good weld by hand. The welding process consists of the following steps:

- Preheat: Push the pipe/fittings against the heating plate until the required welding bead has been formed (refer to appendix B)
- Heating up: Hold the pipe/fittings against the heating plate with no pressure (for time see appendix B)
- Change over, welding and cooling: When the spigots are thoroughly heated both parts need to be joined as quick as possible using a gently buildup of pressure. Moving the parts during or after cool down is not permitted. Keep the parts jointed together under pressure as long as the welding bead is still plasticized. Ensure that the joint is allowed to cool down without any additional load.

Using a butt-welding machine gives a better result under all circumstances.

Machining the surface

Both sides should be machined until they run parallel. When machining is finished, open the carriages (the plastic shavings must be continuous and uniform in both sides to weld).

Verify the alignment between the machined surfaces. remove the plastic shaving. Do not touch and keep machined surfaces clean.

! Without removing the oxygen layer a weld cannot be guaranteed. The oxidation layer will form again within one hour.

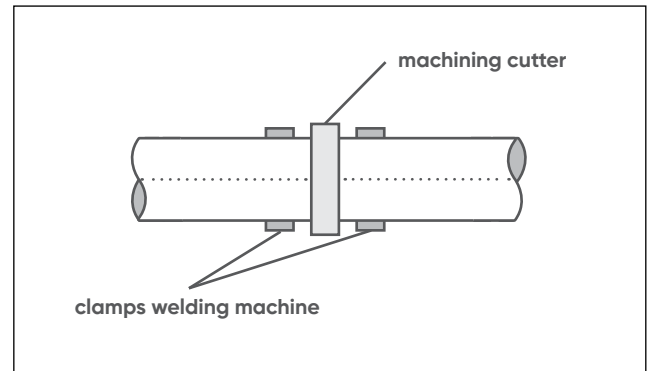

Illustration 7.1 Machining the surface

Preheating under pressure

During heating, the two spigot ends must be placed under low pressure to the heating element (0,2N/mm²). Through contact with the heating element a welding bead will form. The size of the bead is a good indication that the appropriate pressure and time is used. The correct welding bead height and preheating pressure is provided in appendix B.

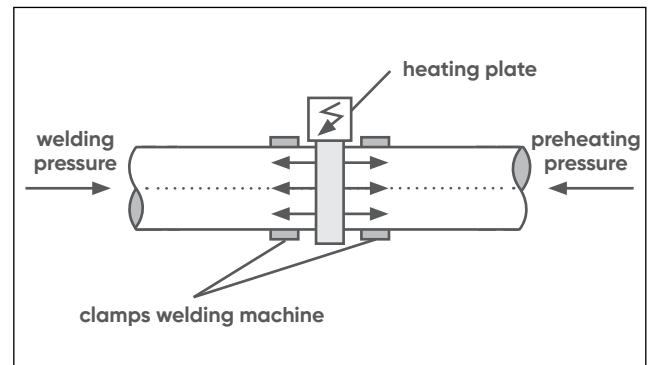

Illustration 7.2 Preheating under pressure

Heating with less pressure

HDPE is a good insulator, therefore at this stage it is necessary that the correct heating depth of the pipe ends is obtained. Only a small amount of pressure 0,01 N/mm² is required to maintain the contact of the ends with the heating element. The heat will gradually spread through the pipe/fitting end. The size of the bead will increase a little. The time and pressure needed for this phase can be found in appendix B.

Change over

Remove the heating element from the joining areas and immediately join the two end together. Do not push the ends abruptly onto each other. The removal of the heating element needs to be done quickly to prevent the ends from cooling down. The maximum allowed change over times can be found in appendix B.

Welding and cooling

After the jointing areas have made contact they should be joined with a gradual increase in pressure up to the specified value. The build-up of pressure should be done linear and not differ more than $0,01 \text{ N/mm}^2$. When the buildup occurs too fast the plastic material will be pushed away. Contrary, when the buildup is too slow the material cools down before a homogenous weld is formed. In both cases the quality of the weld is questionable. Keep the specified welding pressure at a constant level during the complete cooling period. There must not be any load or strain at the joint.

! It is not allowed to artificially cool the joint!

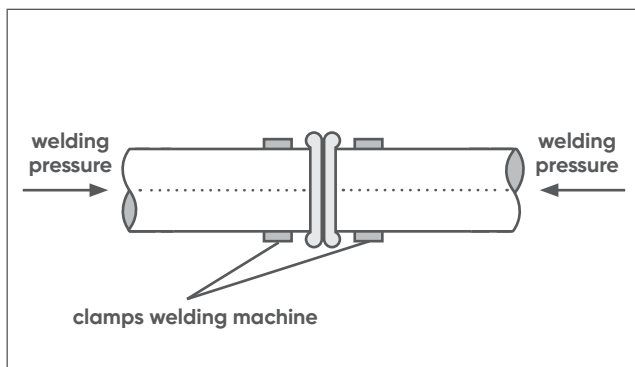

Illustration 7.3

The welded components can be removed from the machine when 50% of the cooling period has elapsed providing the following criteria are met:

- Prefabrication in workplace conditions.
- No load and strain placed on the joint.
- No additional load and strain when the fitting is removed from the clamping equipment.

! The weld may only be subjected to full operational load after the cooling time provided in appendix B has elapsed.

Welding by hand

The welding process when welding by hand is in general the same as the welding process by using a machine. The following steps are to be considered

- 1. Preheating:** Push the pipe/fitting against the heating plate until the required welding bead has formed (for height of the welding bead see appendix B - welding parameters).
- 2. Heating up:** Push the pipe/fitting against the heating plate until the required welding bead has formed (for height of the welding bead see appendix B).
- 3. Change over:** As the spigots are thoroughly heated up both parts need to be joined. It is important to minimize the change over time as much as possible. (the maximum allowed change over time is given in appendix B).
- 4. Welding:** The jointing has to be carried out accurately. Moving the parts during and after jointing is not possible. (the height of the welding bead is given in appendix B).
- 5. Cooling:** Keep the parts jointed together under pressure as long as the welding bead is still plasticized. The joint needs to cool down without any additional load. The use of a support structure is recommended when jointing long pipe parts.

! The use of a butt-welding machine is highly preferable and will give better and more consistent results.

Evaluating the butt-weld joint

For evaluation of the butt weld on the job site visual inspection methods can be used. Additional testing can be done using both destructive and non-destructive evaluation methods. For these evaluation methods special equipment may be necessary. For a first visual evaluation consider the following factors:

Shape of the welding bead

The shape of the welding bead is an indication for proper operation of the welding process. Both welding beads should have the same shape and size. The width of the welding bead should be approximately $0,5x$ the height. The height of the welding bead is provided in appendix B. In illustration 7.4 a good weld is shown with a uniform welding bead.

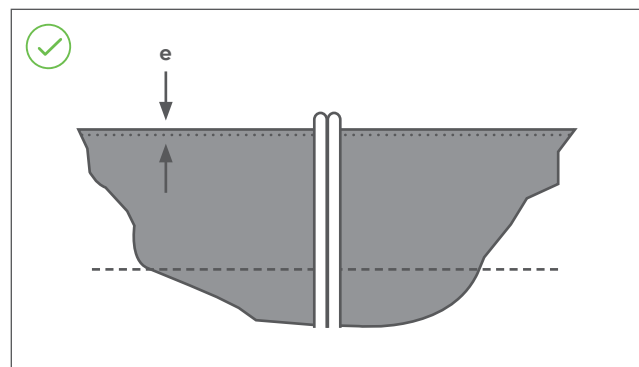

Illustration 7.4 Butt-weld with even welding beads (acceptable)

Differences between the beads can be caused by the difference in HDPE material used in the welded components. Despite the differences in welding bead the butt-weld can be of sufficient strength. In illustration 7.5 a cross-section of a regular, round fusion bead is shown. When differences in welding bead are observed the collar X value is greater than 0.

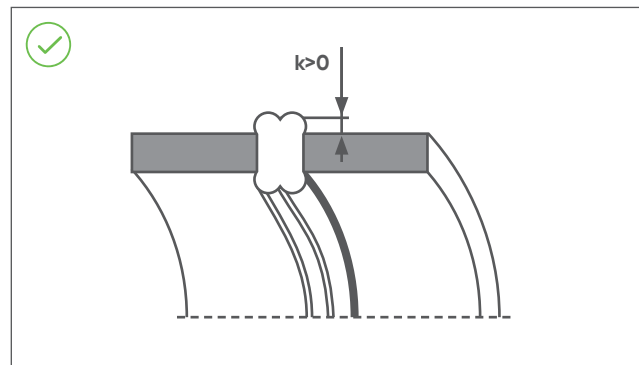

Illustration 7.5 Cross section of a good butt-weld

Alignment

Misalignment between fittings and pipe can occur for several reasons. Oval pipe ends or irregular pipe necking can cause an incorrect fit. If this sagging is less than 10% of the wall thickness the weld can still be classified as acceptable (see illustration 7.6).

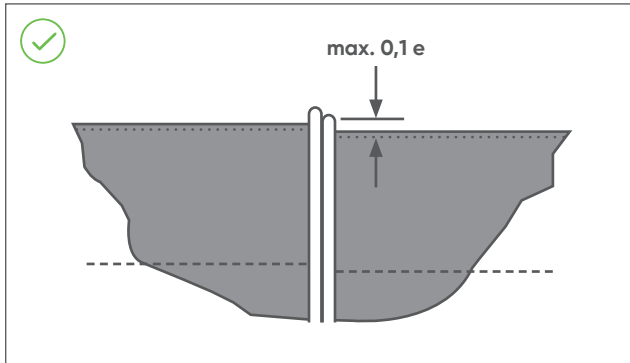

Illustration 7.6 Butt-weld with mis-alignment of pipe (acceptable)

Welding bead size

Illustration 7.7 shows a joint with beads that are too big. The uniformity indicates a good joint preparation. However, heat supply and/or jointing pressure seems to be too high. A purely visual assessment would still classify the weld as acceptable.

! Consider illustration 7.5. When the collar value X is greater than 0 the weld can be classified as acceptable regardless of the welding bead shape.

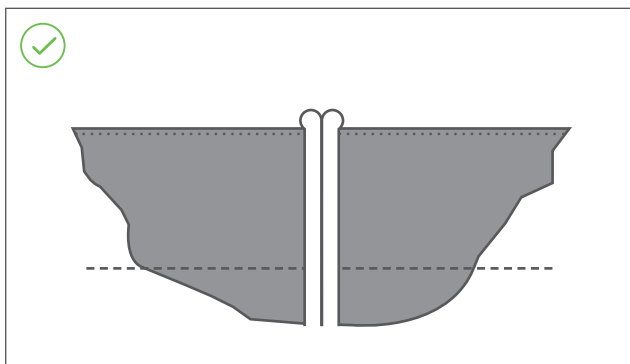

Illustration 7.7 Butt-weld with big welding beads (acceptable)

When there is either insufficient heating up or not enough welding pressure there are hardly any beads. In cases like this thick walled pipes often form shrinking cavities. The weld must be classified as non acceptable

7.3 Electrofusion joint

Electrofusion is a rapid and simple way of permanent jointing. Using the electrofusion coupler and equipment, pipe, fittings and prefabricated pipe section can be efficiently assembled.

! All Akatherm products can be welded by electrofusion unless specifically stated in the product table.

! It is highly recommended to make use of Akatherm electrofusion equipment as compatibility with other welding machines cannot be guaranteed.

Preparations

The following guidelines are to be respected when welding using the electrofusion process:

- Establish a work space where welding can be done without being effect by major weather conditions. The operating temperature of electrofusion control boxes is -10°C/+40°C. Welding above or below these temperatures may not be possible.
- Check if the equipment functions properly. Welding equipment used on site has to undergo regular maintenance. It is necessary to recalibrate the electrofusion control boxes at least every 2 years.
- The resistance wire in the electrofusion coupler lies at the surface for optimal heat exchange. The resistance wires need to be fully covered by the inserted pipe or fitting.

The resistance wires are positioned in the fusion zone. On both sides of the fusion zones, a cold zone prevents the molten HDPE from outpouring thereby containing the fusion process. During the fusion process the pipe/fitting expands and touches the inner coupler wall. The electrofusion joint is made with the pressure caused by the expanding HDPE and the heat from the resistance wires.

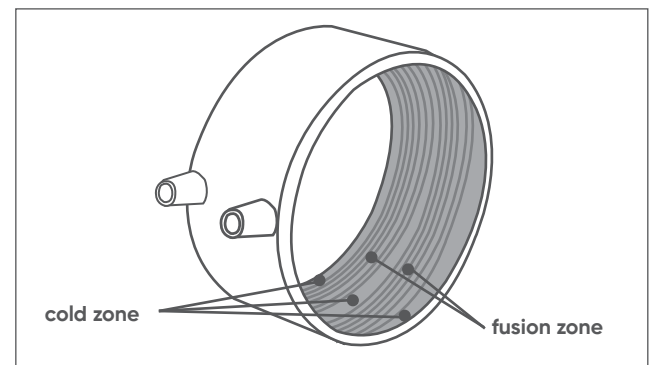

Illustration 7.8

Welding process

In order to make a good electrofusion connection, it is important that the following steps are carried out carefully.

Cut pipe square

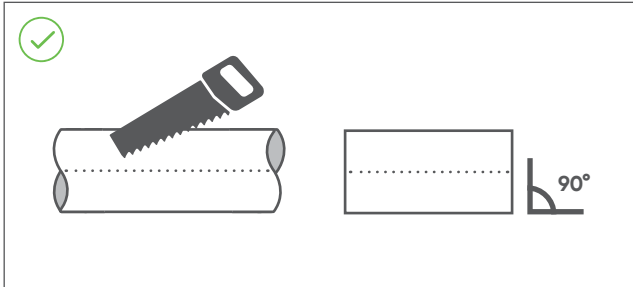

Illustration 79

The pipe ends must be cut square to ensure that the resistance wire in the coupler is completely covered by the pipe or fitting

! After cutting the pipe ensure that burrs are removed.

Mark surface for scraping

Mark insertion depth to ensure that across the full welding zone the oxidized layer will be removed.

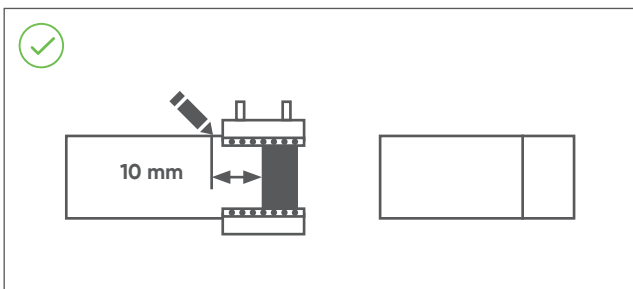

Illustration 710

Scrape pipe and mark insertion depth

The full outer surface of the pipe that will be covered by the coupler must be scraped, preferably using a rotating scraper to ensure even peeling. Scraping depth must be approximately 0,2 mm deep to remove any surface oxidation. The insertion depth should be marked again to safeguard full insertion.

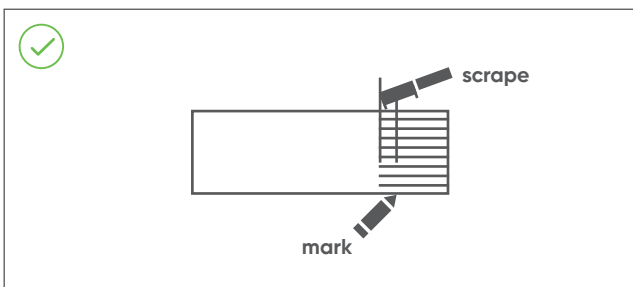

Illustration 711

! Without removing the oxidation layer a weld cannot be guaranteed. The oxidation layer will form again within one hour. The electrofusion needs to be made right after scraping the ends.

Clean electrofusion coupler

Before assembling the pipes into the coupler ensure that all to be welded surfaces are clean and dry and that nothing has been left inside the pipe or fitting. Residual material may ignite during welding, creating a potential fire hazard.

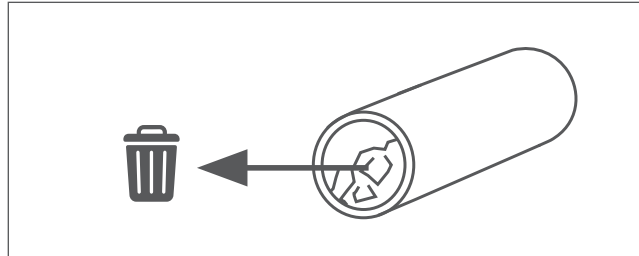

Illustration 712

! Before welding clean the electrofusion coupler and the spigot ends with paper and a pre-approved cleaning solution. Use cleaning wipes only once. Ensure 100% evaporation and that the weld surfaces are clean and dry before assembling. Do not touch the inside of the electrofusion coupler or outside of the spigot ends after cleaning!

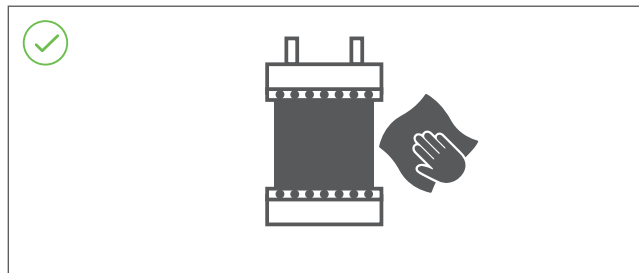

Illustration 713

Insert pipe/fitting

! Insert pipe/fitting until marked line.

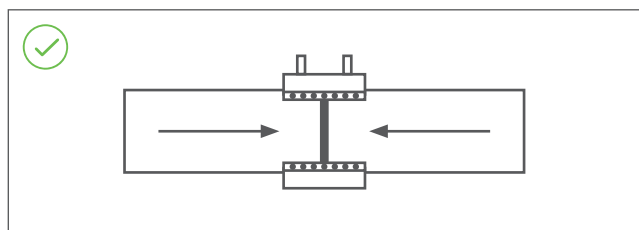

Illustration 714

Ensure that the pipe is pushed into the coupler as straight as possible up to the marked insertion depth. This will ensure that all the wires are covered with HDPE during the fusion cycle. Misalignment will cause extra load on the fusion zone causing additional HDPE to melt resulting in the outpouring of HDPE or wire movement.

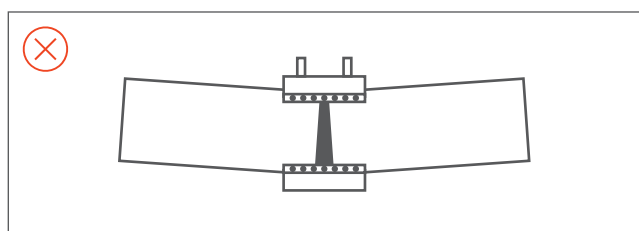

Illustration 715

Do not touch heating wires when control box is connected.

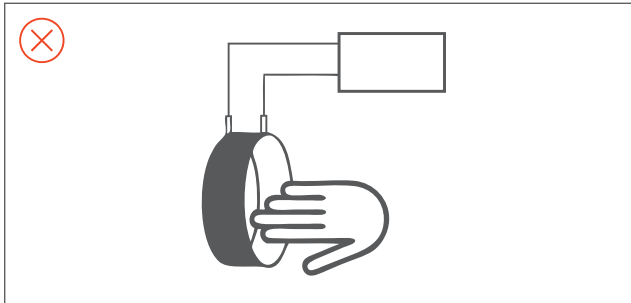

Illustration 7.16

The movement of the pipe can cause melted HDPE to flow out of the joint. This can result in wire movement and possibly a short circuit and thus a bad weld or fire hazard.

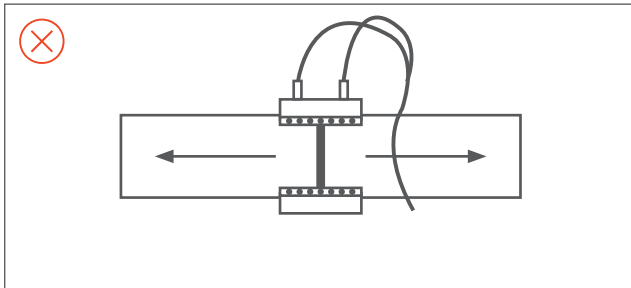

Illustration 7.17

When an electrofusion coupler is used as a repair coupler the center stop is to be removed. This may result in the coupler sliding down when placed vertically. Ensure that the coupler cannot move. Movement may result in short circuit and thus a bad weld or fire hazard.

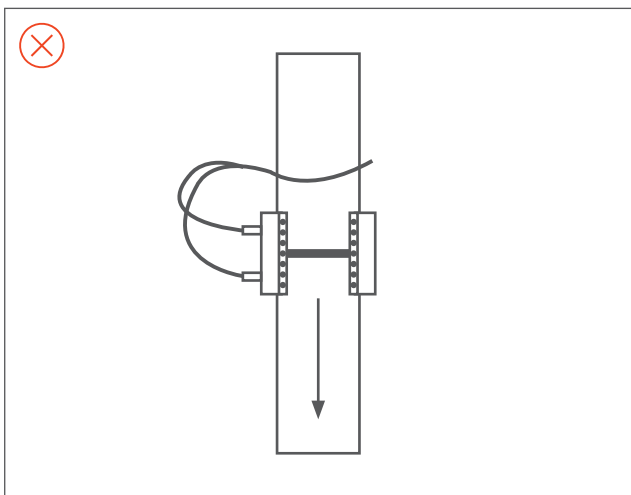

Illustration 7.18

An additional load on the vertical pipe will transfer extra HDPE material to the fusion zone. This will cause movement of the wires and possibly a short circuit and thus a bad weld or fire hazard.

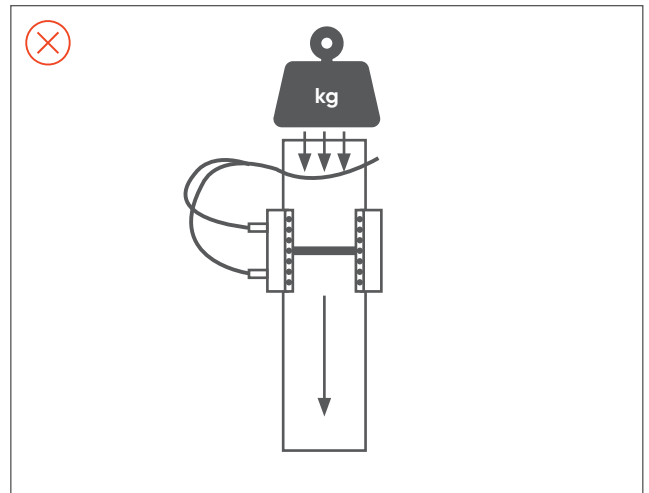

Illustration 7.19

Welding electrofusion coupler and cooling down

After connecting the cables of the control box the fusion process can be commenced by pushing the start button. Both the CB315 and CB160 control boxes adapt the welding time to the ambient temperature. When it is colder than 20°C the welding time is extended and when the ambient temperature exceeds 20°C the welding time is shortened. Welding below an ambient temperature of -10°C is not recommended.

Ambient temperature °C	40-160 mm	200 - 315 mm
-10	97 s	482 s
-5	95 s	469 s
0	92 s	455 s
5	90 s	442 s
10	87 s	428 s
15	84 s	415 s
20	82 s	401 s
25	79 s	388 s
30	77 s	374 s
35	74 s	361 s
40	72 s	347 s
45	69 s	334 s
50	66 s	320 s

Table 7.2 welding time

Cooling times for the 40-160 range are 20 minutes, whilst a cooling time of 30 minutes has to be respected for the 200-315 range products. The cooling period can be reduced by 50% when there is no additional load or strain during cooling (in workshop setting)

Don't weld a coupler twice.

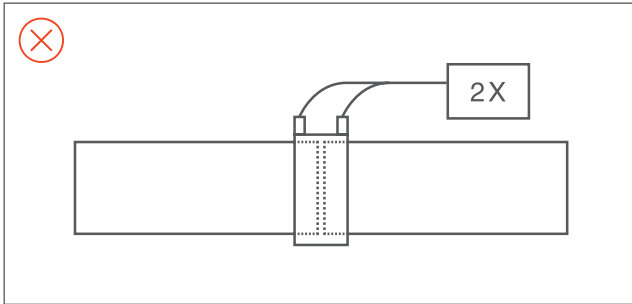

Illustration 7.20

During the fusion cycle the right amount of energy is put into the fusion zones. A second fusion cycle would put so much energy into the joint causing the HDPE to melt extensively. This will cause movement of the wires and possibly a short circuit. In the extreme case it may even cause fire.

Assessing an electrofusion weld

Compared to a butt-weld, it is harder to judge a good electrofusion weld. The welding indicators on the electrofusion coupler provide only an indication if the weld has actually been executed. However, they do not guarantee the integrity of the joint. The amount of movement of the pop-out depends on several factors including the size tolerances of the components and any ovality of the pipe or fitting.

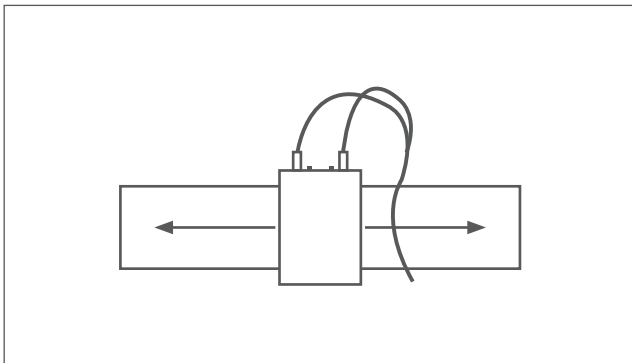

Illustration 7.21

A joint can be marked o.k. when the welding indicators are protruded, all welding preparations such as marking insertion depth, scraping, making sure that there was no additional load during welding and cooling have been executed successfully. If a significant quantity of melt flows out from the fitting after welding, there may be a misalignment of the components, the tolerances may be excessive or a second welding may have accidentally occurred. The integrity of such a joint is suspicious.

Please note that the fitting will become too hot to touch during the welding process. The temperature will continue to increase for some time after the fusion process has been completed.

Deformation

A too big deformation can cause problems during assembly and welding of the components. The maximum allowed deformation of pipe or fitting spigot is $0,02 \times d_1$. This results in a maximum difference between the largest and smallest diameter corresponding with table 7.3. The pipe or fitting spigot needs to be "rounded" using clamps when the deformation is larger.

diameter d_1 (mm)	$d_1 \text{ max} - d_1 \text{ min}$ (mm)
40	1,0
50	1,0
56	1,0
63	1,0
75	1,5
90	2,0
110	2,0
125	2,5
160	3,0
200	4,0
250	5,0
315	6,0

Table 7.3 Deformation pipe

7.4 Rubber ring joints

Plug in joint

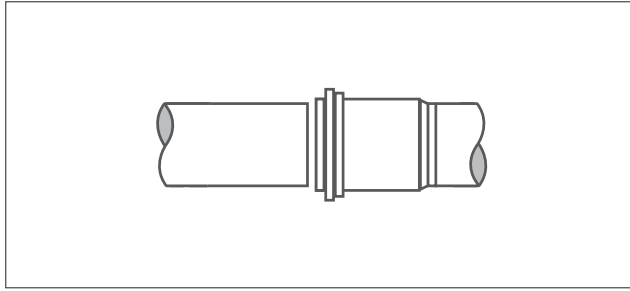

Illustration 7.22

A plug-in joint is an easy to make, detachable and not pull-tight jointing method. Additionally, expansion sockets allow for expansion compensation in the piping system using the same easy to make joint.

Snap joint

For making pull-tight rubber ring joint connections, snap sockets are available. These sockets are rubber ring joints with an additional snap ring which provides, in combination with a groove in the pipe, a pull-tight connection.

Jointing process

1. Cut pipe square and remove burrs

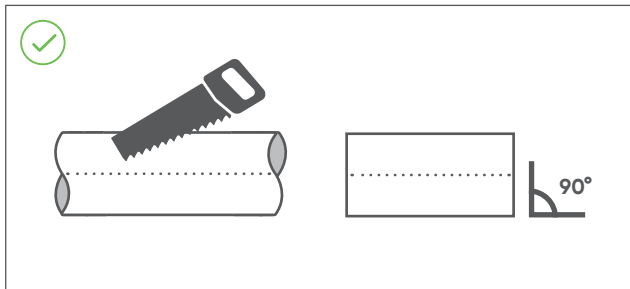

Illustration 7.23

2. Mark insertion depth

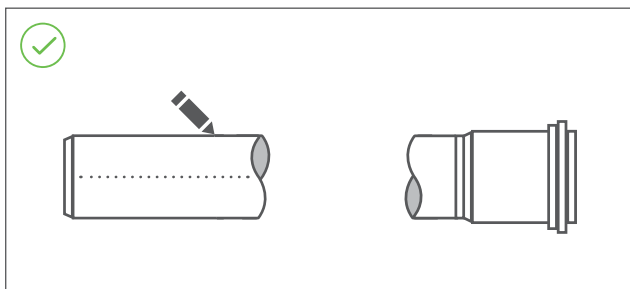

Illustration 7.24

Expansion socket

An expansion socket is used to accommodate the expansion and contraction of a pipe system.

The insertion depth is marked on the socket for both ambient temperatures of 0° and 20°C. For detailed information on insertion depth expansion and socket calculation see paragraph 7.4.

3. chamfer pipe end

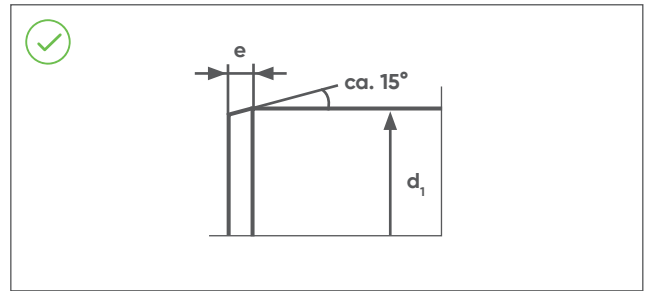

Illustration 7.25 Plug-in joint

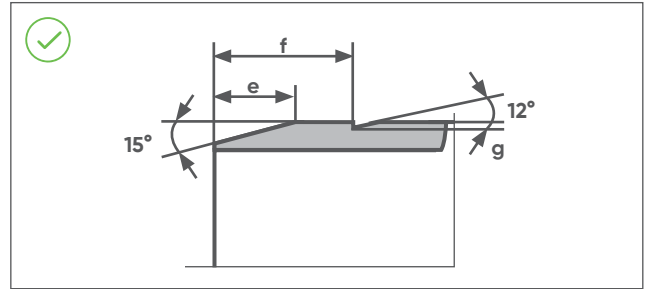

Illustration 7.26 Snap joint

The pipe-ends needs to be chamfered under an angle of 15°. A chamfering tool should be used to get an even cut and chamfer.

When using snap joints a groove needs to be cut under an angle of 12°. The correct dimension can be found in table 7.5. To get an even cut and chamfer it is recommended to use an Akatherm groove cutter.

! When no groove is made, the Akatherm snap sockets are detachable like a non pull-tight joint.

d ₁ (mm)	e	f	g
40	5	15	1
50	5	15	1
56	5	15	1
63	5	15	1
75	5	15	1
90	6	15	1
110	8	15	1
125	9	15	1
160	11	15	1
200	11	30	2
250	15	30	2
315	18	50	3

Table 7.4 Dimensions chamfer and groove

4. Make joint

Lubricate the pie end and insert the pipe up to the marked insertion dept. When jointing a snap joint a distinguished click can be heard when the snap ring is engaged to the groove.

8 Product range

The following pages provide an overview of the Akasison product range. This includes:

- Roof technology
- Fixing technology
- Pipes
- Fittings
- Tools
- Spare parts

8.1 Dimensions

The dimensions of the pipes and fittings in the product tables are all in mm unless otherwise stated. The European standard EN12056 has been applied since 2001 and replaces local standards. EN12056 dimensions are based on the outside diameter, compared with wall thickness.

DN	e (S12,5)	Application
40	3	BD
50	3	BD
56	3	BD
63	3	BD
75	3	BD
90	3,5	BD
110	4,2	BD
125	4,8	BD
160	6,2	BD
200	7,7	BD
250	9,6	BD
315	12,1	BD

Table 8.1

DN	e (type S16)	Application
200	6,2	B
250	7,7	B
315	9,7	B

Table 8.2

Scope application B = inside the building structure

Scope application BD = inside and buried outside the building structure

8.2 Pipe

Akatherm HDPE pipes are produced according to EN1519.

Akatherm HDPE pipes are suitable for applications in which the temperature of the pipe can get relatively high, or vary considerably.

Akatherm HDPE pipe has a standard length of 5 m and is produced to high quality standards with many international approvals.

8.3 Electrofusion

Aliaxis Nederland products can be welded by electrofusion unless stated otherwise in the product table. Electrofusion is the preferred method of on-site jointing.

8.4 Butt welding and the k-dimension

All Aliaxis Nederland products can be welded using this jointing method. Fittings can be shortened by up to the k-dimension (when indicated in the catalogue), thus allowing butt welding on a standard butt welding machine.

Only identical materials can be welded.

8.5 Abbreviations

Abbreviation	
A	Cross section area flow
Code	Article number
D	External dimension fitting part
d₁, d₂ ...	External dimension fitting/pipe
DN	Nominal size
e	Wall thickness
k₁, k₂ ...	Maximum length for shortening fittings
L	Total length fitting
l₁, l₂ ...	Partial length of fitting
S	Pipe class according to ISO-S (SDR-1)/2
SDR	Ratio diameter/wall thickness d ₁ /e

Table 8.3

8.6 Handling and storage

Pipes

The high impact strength of Akatherm HDPE provides some protection against damage, but care should still be taken at all stages of handling, transportation and storage. Pipe must be transported by a suitable vehicle and properly loaded and unloaded. Whenever possible it should be moved by hand or mechanical lifting equipment. Pipes must not be dragged across the ground. The storage should be flat, level, and free from sharp objects.

Lengths

Pipe lengths stored individually should be stacked in a pyramid of not more than one metre high, with the bottom layer fully restrained by wedges. Where possible, the bottom layer of pipes should be laid on timber battens up to one metre apart. On site, pipes may be laid out individually. Where appropriate, protective barriers should be placed with adequate warning signs and lamps.

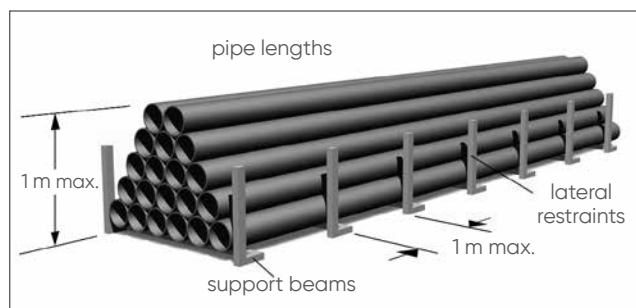

Image 8.1

Bundles

Bundled packs of pipe should be stored on clear, level ground with the battens supported from the outside by timber or concrete blocks. For safety, bundled packs should not be stacked more than 3 m high. Smaller pipes may be nested inside larger pipes. Side bracing should be provided to prevent stack collapse.

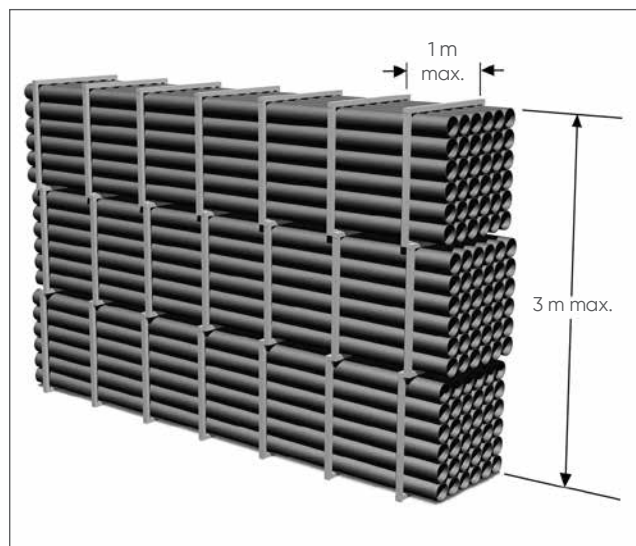

Image 8.2

Fittings

Fittings and electrofusion couplers need to be stored in a dry place. To prevent oxidation and contamination, it is recommended to leave fittings in their original packaging until required for use.

Tools

All tools - especially electrical - ones must be protected against moisture and dust, and should not be dropped.

Recycling residual waste

To comply with regulations, residual waste materials should be recycled:

- PE/electrofusion couplers: recycle/residual waste
- Carton boxes : recycled paper
- Plastic containers : residual waste
- Chips : residual waste
- Cleaning cloths : residual waste

9 Roof/gutter outlets, air baffles, emergency sets







Roof outlet	Membrane	Material	Colour	Page
	Bitumen	Stainless steel	Brushed steel	46
	PVC	PVC	Light grey	48
	FPO-PP	PP	Dark grey	50
	FPO-PE	PE	Blue	52
	Clamp	ASA	Black	54

Table 91

Air baffle for roof outlet							
							
Code	747550	749053	747551	749051	747554	749054	747552
Type	Primary	Primary	Emergency		Emergency		Emergency
Air baffle diameter [mm]	Ø250	Ø420	Ø250		Ø320		Ø250
Connected pipe [mm]	Ø75/Ø90	Ø75/Ø90	Ø75	Ø90	Ø75	Ø90	Ø75/Ø90
Suitability outlet 75	++	++	++	x	++	x	++
Suitability outlet 90	+	++	x	++	x	++	++
Page	60	60	61	61	62	62	63

- ++ Excellent
- + Sufficient
- x Not possible

Table 92

Gutter outlet	Gutter type	Fixing method to gutter	Ø 75 mm	Ø 90 mm
	Metal gutter	Soldering	747800 page 64	749800 page 65
	Metal gutter	Clamping with nuts and bolts	747808 page 64	749808 page 65
	Metal gutter Covered with roofing membrane	Soldering	747802 page 64	-
	Concrete	Knock-in bolts	747801 page 66	749801 page 66
	Concrete Covered with roofing membrane	Knock-in bolts	747803 page 66	-

Table 93

Emergency sets for gutter outlet	Range elevation	XL75	XL90
	50 mm	747591 page 67	-
	55 – 85 mm	747592 page 67	-
	90 mm	-	749051 page 61
	90 mm	-	747552 page 63

Table 94

Base roof outlet XL75 metal for bitumen

with 75 mm connection

Stainless steel/HDPE

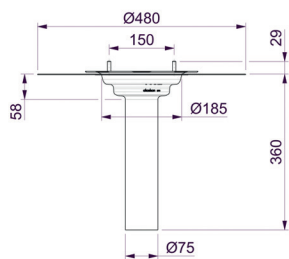

d ₁	Code	Type	Description
75	747342	Akasison XL75 metal	Metal
75	747343	Akasison XL75 H metal	Metal, heated

Roof outlet without air baffle and leaf guard. Suitable for bitumen roof sealing membranes.

Scope of delivery	: Base outlet with stud protectors. Connection to HDPE. Heated models incl. self regulating 230V heating element, cable length 1 m. Fireproof lid for protection during application of roofing membrane. Optional without extra charge EPS insulating block.
Not included	: Siphonic roof drainage air baffle. Combined with an Akasison air baffle, the combination is according to EN1253 for siphonic drainage. Suitable air baffle's: 747550, 747551, 747552, 747554, 747555, 747595.
Application	: Cold roof/warm roof.
Insulation thickness	: Insulation between 60 and 330 mm.
Connection to HDPE	: Electrofusion coupler d75 mm Code 410795.
Drilling core size	: Ø □ 80 mm. 140 mm in combination Code 747711 and 747713. 160 mm in combination Code 747723.
Outlet	: d ₁ = 75 mm.
Material	: stainless steel, HDPE.

Base roof outlet XL90 metal for bitumen

with 90 mm connection

Stainless steel/HDPE

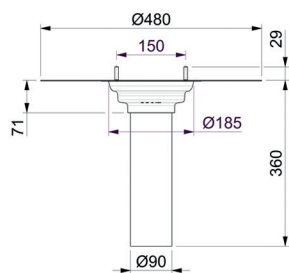

d ₁	Code	Type	Description
90	749342	Akasison XL90 metal	Metal
90	749343	Akasison XL90 H metal	Metal, heated

Roof outlet without air baffle and leaf guard. Suitable for bitumen roof sealing membranes.

Scope of delivery	: Base outlet with stud protectors. Connection to HDPE. Heated models incl. self regulating 230V heating element, cable length 1 m. Fireproof lid for protection during application of roofing membrane. Optional without extra charge EPS insulating block.
Not included	: Siphonic roof drainage air baffle Combined with an Akasison air baffle, the combination is according to EN1253 for siphonic drainage. Suitable air baffle's: 747550, 747551, 747552, 747554, 747555, 747595.
Application	: Cold roof/warm roof.
Insulation thickness	: Insulation between 60 and 330 mm.
Connection to HDPE	: Electrofusion coupler d90 mm Code 410995.
Drilling core size	: Ø □ 100 mm. 140 mm in combination Code 749711 and 749713. 160 mm in combination Code 749723.
Outlet	: d ₁ = 90 mm.
Material	: stainless steel, HDPE.

Roof outlet XL75 metal for bitumen horizontal

HDPE/ASA/Stainless steel

with 75 mm horizontal connection

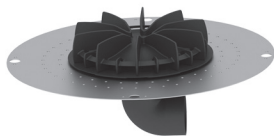

d ₁	Code	Type	Description
75	747382	Akasison XL75 HR metal	Metal
75	747383	Akasison XL75 HR H metal	Metal, heated

Metal roof outlet acc. to EN 1253 for bitumen roof membranes for siphonic roof drainage systems. Suitable for homogeneous securing/sealing of bitumen roof sealing membrane.

Scope of delivery : Air baffle with integrated leafguard (UV-stabilized).
 ASA anti punching for protection of bitumen membrane.
 Horizontal connection to HDPE.
 Heated models incl. self regulating 230V heating element, cable length 1 m.
 Fireproof lid for protection during application of roofing membrane.

Application : Cold roof/warm roof.
 Connection to HDPE : with electrofusion coupler d75 mm Code 410795.
 Outlet : d₁ = 75 mm horizontally.
 Performance : 1-20,0 l/s.
 Material : Stainless steel, HDPE, ASA (UV-stabilized).

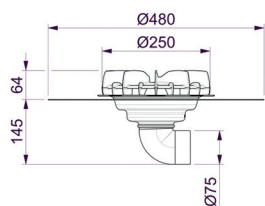

Base roof outlet XL75 PVC

with 75 mm connection

Stainless steel/HDPE/PVC

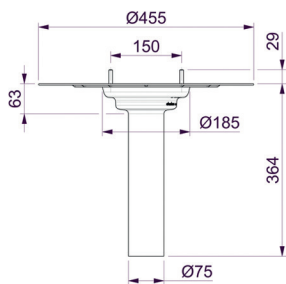

d ₁	Code	Type	Description
75	747544	Akasison XL75 PVC	PVC foil
75	747545	Akasison XL75 H PVC	PVC foil, heated

Roof outlet without air baffle and leaf guard. Suitable for PVC membranes.

Scope of delivery	: Base outlet with stud protectors. Connection to HDPE. Heated models incl. self regulating 230V heating element, cable length 1 m.
Not included	: Siphonic roof drainage air baffle Combined with an Akasison air baffle, the combination is according to EN1253 for siphonic drainage. Suitable air baffle's: 747550, 747551, 747552, 747554, 747555, 747595.
Application	: Cold roof/warm roof.
Insulation thickness	: Between 60 and 330 mm.
Connection to HDPE	: Electrofusion coupler d75 mm Code 410795.
Drilling core size	: Ø □ 80 mm. 140 mm in combination Code 747711 and 747713. 160 mm in combination with Code 747723.
Outlet	: d ₁ = 75 mm.
Material	: stainless steel, PVC, HDPE.

Base roof outlet XL90 PVC

with 90 mm connection

Stainless steel/HDPE/PVC

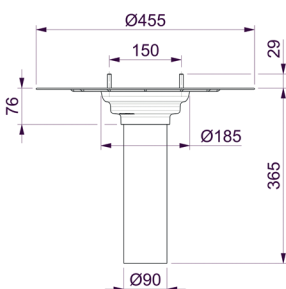

d ₁	Code	Type	Description
90	749044	Akasison XL90 PVC	PVC
90	749045	Akasison XL90 H PVC	PVC heated

Roof outlet without air baffle and leaf guard. Suitable for PVC membranes.

Scope of delivery	: Roof outlet with PVC clamp flange or connection with PVC roof sealing. Connection to HDPE. Heated models incl. self regulating 230V heating element, cable length 1 m.
Not included	: Siphonic roof drainage air baffle Combined with an Akasison air baffle, the combination is according to EN1253 for siphonic drainage. Suitable air baffle's: 747550, 747551, 747552, 747554, 747555, 747595.
Application	: Cold roof/warm roof.
Insulation thickness	: between 60 and 330 mm.
Connection to HDPE	: Electrofusion coupler d90 mm Code 410995.
Drilling core size	: Ø □ 100 mm. 140 mm in combination Code 749711 and 749713. 160 mm in combination with Code 749723.
Outlet	: d ₁ = 100 mm.
Material	: stainless steel, PVC, HDPE.

Roof outlet XL75 PVC horizontal

with 75 mm horizontal connection

HDPE/ASA/PVC

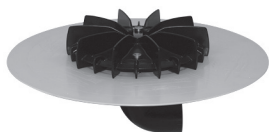

d _i	Code	Type	Description
75	747584	Akasison XL75 HR PVC	PVC
75	747585	Akasison XL75 HR H PVC	PVC, heated

Roof outlet with PVC clamp flange acc. to EN 1253 for siphonic roof drainage systems. Suitable for homogeneous securing/sealing of PVC roof sealing membrane.

Scope of delivery : Air baffle with integrated leafguard (UV-stabilized).
 Roof outlet incl. PVC flange.
 Horizontal connection to HDPE.
 Heated models incl. self regulating 230V heating element, cable length 1 m.

Application : Cold roof/warm roof.
 Connection to HDPE : with electrofusion coupler d75 mm Code 410795.

Outlet : d_i = 75 mm horizontally.

Performance : 1-20,0 l/s.

Material : PVC, HDPE, ASA (UV-stabilized).

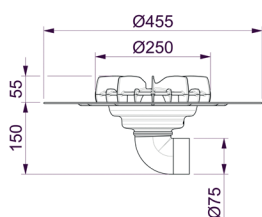

Base roof outlet XL75 PP

with 75 mm connection

Stainless steel/HDPE/PP

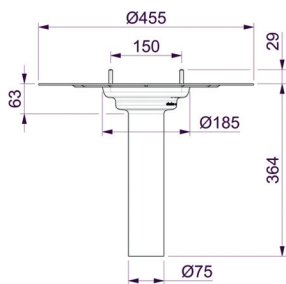

d ₁	Code	Type	Description
75	747546	Akasison XL75 FPO/TPO - PP	FPO/TPO
75	747547	Akasison XL75 H FPO/TPO - PP	FPO/TPO, heated

Roof outlet without air baffle and leaf guard. Suitable for FPO/TPO membranes.

Scope of delivery : Roof outlet with PP clamp flange for connection with FPO/TPO roof sealing membrane.
Connection to HDPE.

Heated models incl. self regulating 230V heating element, cable length 1 m.

Not included : Siphonic roof drainage air baffle
Combined with an Akasison air baffle, the combination is according to EN1253 for siphonic drainage.

Suitable air baffle's: 747550, 747551, 747552, 747554, 747595.

Application : Cold roof/warm roof.

Tested membranes : Firestone, Sintofol ST, Sintofol RG, Soprema Flagon

Insulation thickness : Between 60 and 330 mm.

Connection to HDPE : Electrofusion coupler d75 mm Code 410795.

Drilling core size : Ø □ 80 mm.

140 mm in combination with Code 747711 and 747713.

160 mm in combination with Code 747723.

Outlet : d₁ = 75 mm.

Material : Stainless steel, PP, HDPE.

Base roof outlet XL90 PP

with 90 mm connection

Stainless steel/HDPE/PP

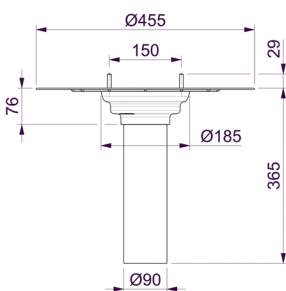

d ₁	Code	Type	Description
90	749046	Akasison XL90 FPO/TPO	FPO/TPO
90	749047	Akasison XL90 H FPO/TPO	FPO/TPO, heated

Roof outlet without air baffle and leaf guard. Suitable for FPO/TPO membranes.

Scope of delivery : Roof outlet with PP clamp flange for connection with FPO/TPO roof sealing membrane.
Connection to HDPE.

Heated models incl. self regulating 230V heating element, cable length 1 m.

Not included : Siphonic roof drainage air baffle
Combined with an Akasison air baffle, the combination is according to EN1253 for siphonic drainage.

Suitable air baffle's: 747550, 747551, 747552, 747554, 747555, 747595.

Application : Cold roof/warm roof.

Tested membranes : Firestone, Sintofol ST, Sintofol RG, Soprema Flagon

Insulation thickness : Between 60 and 330 mm.

Connection to HDPE : Electrofusion coupler d90 mm Code 410995.

Drilling core size : Ø □ 100 mm.

140 mm in combination Code 749711 and 749713.

160 mm in combination with Code 749723.

Outlet : d₁ = 90 mm.

Material : Stainless steel, PP, HDPE.

Roof outlet XL75 PP horizontal

with 75 mm horizontal connection

HDPE/ASA/PP

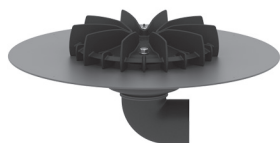

d _i	Code	Type	Description
75	747586	Akasison XL75 HR FPO/TPO - PP	FPO/TPO
75	747587	Akasison XL75 HR H FPO/TPO - PP	FPO/TPO, heated

Roof outlet with PP clamp flange acc. to EN 1253 for siphonic roof drainage systems. Suitable for homogeneous securing/sealing of FPO/TPO roof sealing membrane.

Scope of delivery : Air baffle with integrated leafguard (UV-stabilized).
 Roof outlet incl. FPO/TPO flange.
 Horizontal connection to HDPE.
 Heated models incl. self regulating 230V heating element, cable length 1 m.

Application : Cold roof/warm roof.
 Connection to HDPE : with electrofusion coupler d75 mm Code 410795.

Outlet : d_i = 75 mm horizontally.

Performance : 1-20,0 l/s.

Material : PP, HDPE, ASA (UV-stabilized).

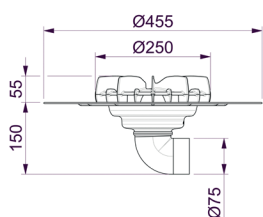

Base roof outlet XL75 PE

with 75 mm connection

Stainless steel/HDPE

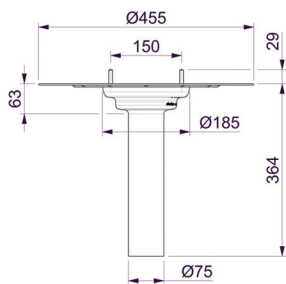

d ₁	Code	Type	Description
75	747548	Akasison XL75 FPO/TPO - PE	FPO/TPO
75	747549	Akasison XL75 H FPO/TPO - PE	FPO/TPO, heated

Roof outlet without air baffle and leaf guard. Suitable for PE membranes.

Scope of delivery	: Roof outlet with PE clamp flange for connection with PE roof sealing membrane. Connection to HDPE. Heated models incl. self regulating 230V heating element, cable length 1 m.
Not included	: Siphonic roof drainage air baffle Combined with an Akasison air baffle, the combination is according to EN1253 for siphonic drainage. Suitable air baffles: 747550, 747551, 747552, 747554, 747555, 747595.
Application	: Cold roof/warm roof.
Tested membranes	: Köster TPO 2.0, Polyfin® FPO/TPO, Polyfin® FPO/TPO Duo, Schedetal Extrupol® M FPO
Insulation thickness	: between 60 and 330 mm.
Connection to HDPE	: with electrofusion coupler d75 mm Code 410795.
Drilling core size	: Ø □ 80 mm. 140 mm in combination with mounting sleeve Code 747711 and 747713. 160 mm in combination with reinforcement plate fire protection Code 747723.
Outlet	: d ₁ = 75 mm.
Material	: Stainless steel, PE.

Base roof outlet XL90 PE

with 90 mm connection

Stainless steel/HDPE

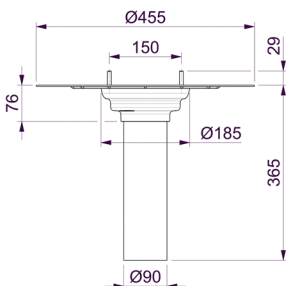
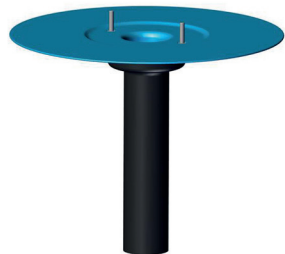

d ₁	Code	Type	Description
90	749048	Akasison XL90 FPO/TPO - PE	FPO/TPO
90	749049	Akasison XL90 H FPO/TPO - PE	FPO/TPO, heated

Roof outlet without air baffle and leaf guard. Suitable for PE membranes.

Scope of delivery	: Roof outlet with PE clamp flange for connection with PE roof sealing membrane. Connection to HDPE. Heated model incl. self regulating 230V heating element, cable length 1 m.
Not included	: Siphonic roof drainage air baffle Combined with an Akasison air baffle, the combination is according to EN1253 for siphonic drainage. Suitable air baffles: 747550, 747551, 747552, 747554, 747555, 747595.
Application	: Cold roof/warm roof.
Insulation thickness	: Between 60 and 330 mm.
Connection to HDPE	: Electrofusion coupler d90 mm Code 410995.
Drilling core size	: Ø □ 100 mm. 140 mm in combination Code 749711 and 749713. 160 mm in combination with Code 749723.
Material	: Stainless steel, HDPE.

Roof outlet XL75 PE horizontal

with 75 mm horizontal connection

HDPE/ASA/PE

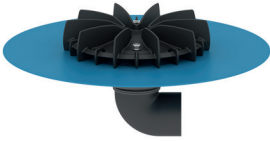

d _i	Code	Type	Description
75	747588	Akasison XL75 HR FPO/TPO - PE	FPO/TPO
75	747589	Akasison XL75 HR H FPO/TPO - PE	FPO/TPO, heated

Roof outlet with PE clamp flange acc. to EN 1253 for siphonic roof drainage systems. Suitable for homogeneous securing/sealing of FPO/TPO roof sealing membrane.

Scope of delivery : Air baffle with integrated leafguard (UV-stabilized).
 Roof outlet incl. PE flange.
 Horizontal connection to HDPE.
 Heated models incl. self regulating 230V heating element, cable length 1 m.

Application : Cold roof/warm roof.
 Connection to HDPE : with electrofusion coupler d75 mm Code 410795.

Outlet : d_i = 75 mm horizontally.

Performance : 1-20,0 l/s.

Material : PE, HDPE, ASA (UV-stabilized).

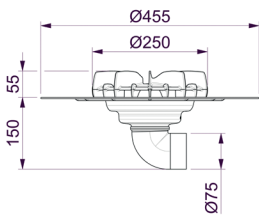

Base roof outlet XL75 clamp flange

with 75 mm connection

HDPE/stainless steel

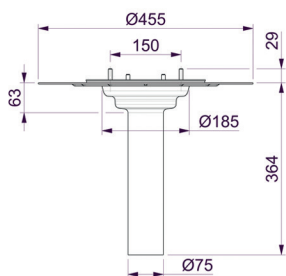

d ₁	Code	Type	Description
75	747540	Akasison XL75 C	Clamp flange
75	747541	Akasison XL75 HC	Clamp flange, heated

Roof outlet without air baffle and leaf guard. Suitable for mechanical securing/sealing of roof sealing membrane.

Scope of delivery	: Base outlet with stud protectors. Connection to HDPE. Heated models incl. self regulating 230V heating element, cable length 1 m.
Not included	: Siphonic roof drainage air baffle Combined with an Akasison air baffle, the combination is according to EN1253 for siphonic drainage. Suitable air baffle's: 747550, 747551, 747552, 747554, 747555, 747595.
Application	: Cold roof/warm roof.
Insulation thickness	: Between 60 and 330 mm.
Connection to HDPE	: Electrofusion coupler d75 mm Code 410795.
Outlet	: d ₁ = 75 mm.
Drilling core size	: Ø □ 80 mm. 140 mm in combination with mounting sleeve Code 747711 and 747713. 160 mm in combination with reinforcement plate fire protection Code 747723.
Material	: stainless steel, HDPE.

Base roof outlet XL90 clamp flange

with 90 mm connection

HDPE/stainless steel

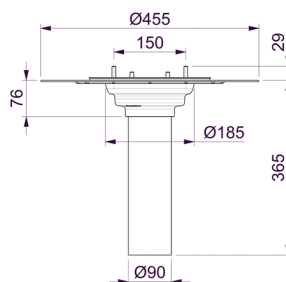

d ₁	Code	Type	Description
90	749040	Akasison XL90 C	Clamp flange
90	749041	Akasison XL90 HC	Clamp flange, heated

Roof outlet without air baffle and leaf guard. Suitable for mechanical securing/sealing of roof sealing membrane.

Scope of delivery	: Base outlet with stud protectors. Connection to HDPE. Heated models incl. self regulating 230V heating element, cable length 1 m.
Not included	: Siphonic roof drainage air baffle Combined with an Akasison air baffle, the combination is according to EN1253 for siphonic drainage. Suitable air baffle's: 747550, 747551, 747552, 747554, 747555, 747595.
Application	: Cold roof/warm roof.
Insulation thickness	: Between 60 and 330 mm.
Connection to HDPE	: Electrofusion coupler d90 mm Code 410995.
Outlet	: d ₁ = 90 mm.
Drilling core size	: Ø □ 100 mm. 140 mm in combination Code 749711 and 749713. 160 mm in combination with Code 749723.
Material	: stainless steel, HDPE.

Roof outlet XL75 HR clamp flange horizontal

HDPE/ASA/stainless steel

with 75 mm horizontal connection

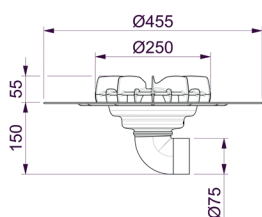

d ₁	Code	Type	Description
75	747580	Akasison XL75 HR C	Clamp flange
75	747581	Akasison XL75 HR H C	Clamp flange, heated

Roof outlet with clamp flange acc. to EN 1253 for siphonic roof drainage systems. Suitable for mechanical securing/sealing of roof sealing membrane.

Scope of delivery	: Air baffle with integrated leafguard (UV-stabilized). Clamp flange with prefixed seal. Connection to HDPE. Heated models incl. self regulating 230V heating element, cable length 1 m.
Application	: Cold roof/warm roof.
Insulation thickness	: 140 mm.
Connection to HDPE	: with electrofusion coupler d75 mm Code 410795.
Outlet	: d ₁ = 75 mm horizontally.
Performance	: 1-20,0 l/s.
Material	: ASA, stainless steel, HDPE.

Akasison XL75 installation socket

HDPE/galvanised steel/stainless steel

according to DIN 18807
SBR and EPDM seal

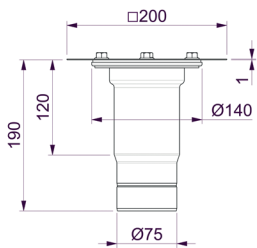

d_1	Code	n	M
75	747713	4	8

Akasison XL75 installation socket for pre-completion building drainage when insulation and roof outlets are not yet installed.

Scope of delivery	: Galvanised plate. HDPE socket with SBR seal. Flange and EPDM seal.
Application	: Warm roof and applications according to DIN 18234
Connection pipe system	: Electrofusion coupler d75 mm Code 410795. Ring groove for snap socket d75 mm Code Nr. 400730.
Outlet	: $d_1 = 75$ mm.
Drilling core size	: $\varnothing \square 140$ mm.
Material	: HDPE, galvanised steel, stainless steel, SBR, EPDM.

n = number of bolts
M = thread

Akasison XL90 installation socket

HDPE/galvanised steel/stainless steel

according to DIN 18807
SBR and EPDM seal

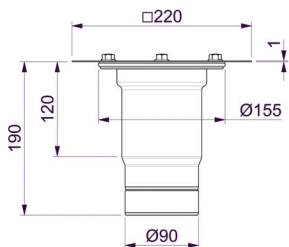

d_1	Code	n	M
90	749713	4	8

Akasison XL90 installation socket for pre-completion building drainage when insulation and roof outlets are not yet installed.

Scope of delivery	: Galvanised plate. HDPE socket with SBR seal. Flange and EPDM seal.
Application	: Warm roof and applications according to DIN 18234
Connection pipe system	: Electrofusion coupler d90 mm Code 410995.
Outlet	: $d_1 = 90$ mm.
Drilling core size	: $\varnothing \square 160$ mm.
Material	: HDPE, galvanised steel, stainless steel, SBR, EPDM.

n = number of bolts
M = thread

Akasison XL75 reinforcement plate without connector

according to DIN 18807
EPDM seal

Galvanised steel/EPDM



	Code		D
	747712		140

Akasison XL75 reinforcement plate according to DIN 18807 for the vapour barrier connection in siphonic roof drainage systems. Applied in insulated metal roofs in combination with roof outlet Akasison XL75. At the top of the metal plate a vapour barrier foil or bitumen can be applied. In combination with specific roofs the metal plate can be used as reinforcing plate.

Scope of delivery : Galvanised plate.
Application : Warm roof and applications acc. to DIN 18234.
Material : Galvanised steel, EPDM.

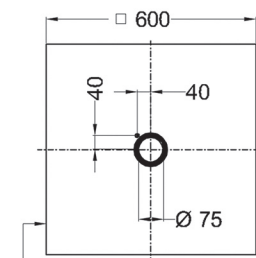

d 1.25

Akasison XL75 reinforcement plate with vapour barrier connection

according to DIN 18807
SBR and EPDM seal

HDPE/galvanised steel



d ₁	Code	n	M
75	747711	4	8

Akasison XL75 reinforcement plate according to DIN 18807 for the vapour barrier connection in siphonic roof drainage systems. Applied in insulated metal roofs in combination with roof outlet Akasison XL75. At the top of the metal plate a vapour barrier foil or bitumen can be applied. In combination with specific roofs the metal plate can be used as reinforcing plate. The HDPE socket can be connected for pre-completion building drainage when insulation and roof outlets are not yet installed.

Scope of delivery : Galvanised plate.
HDPE socket with SBR seal.
Flange and EPDM seal.
Application : Warm roof (Metalleichtbau) and applications acc. to DIN 18234.
Connection pipe system : Electrofusion coupler d75 mm Code 410795.
Ring groove for snap socket d75 mm Code 400730.
Outlet : d₁ = 75 mm.
Drilling core size : Ø □ 140 mm.
Material : HDPE, galvanised steel, SBR, EPDM.

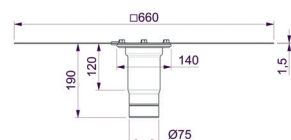

n = number of bolts
M = thread

Akasison XL75 reinforcement plate with vapour barrier connection and fire protection

according to DIN 18234 to 18807
SBR and EPDM seal

HDPE/intumescent material/
galvanised steel/stainless steel

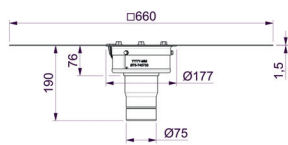
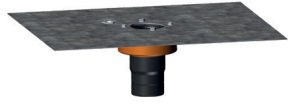

d_1	Code	n	M
75	747723	4	8

Akasison XL75 reinforcement plate according to DIN 18807 for the vapour barrier connection and fire collar according to 18234 in siphonic roof drainage systems. Applied in insulated metal roofs in combination with roof outlet Akasison XL75. At the top of the metal plate a vapour barrier foil or bitumen can be applied. In combination with specific roofs, the metal plate can be used as reinforcing plate. The HDPE socket can be connected for pre-completion building drainage when insulation and roof outlets are not yet installed.

Scope of delivery	: Galvanised plate incl. Akasison fire collar. HDPE socket with SBR seal. Flange and EPDM seal.
Application	: Warm roof (Metalleichtbau) and applications acc. to DIN 18234.
Connection pipe system	: Electrofusion coupler d75 mm Code 410795. Ring groove for snap socket d75 mm Code 400730.
Outlet	: $d_1 = 75$ mm.
Drilling core size	: $\varnothing \square 160$ mm.
Material	: HDPE, galvanised steel, stainless steel, SBR, EPDM.

n = number of bolts
M = thread

Akasison XL90 reinforcement plate with vapour barrier connection

according to DIN 18807
SBR and EPDM seal

HDPE/galvanised steel/stainless
steel

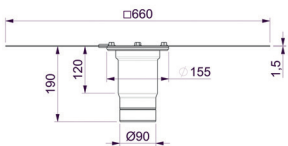

d_1	Code	n	M
90	749711	140	300

Akasison XL90 reinforcement plate according to DIN 18807 for the vapour barrier connection in siphonic roof drainage systems. Applied in insulated metal roofs in combination with roof outlet Akasison XL90. At the top of the metal plate a vapour barrier foil or bitumen can be applied. In combination with specific roofs the metal plate can be used as reinforcing plate. The HDPE socket can be connected for pre-completion building drainage when insulation and roof outlets are not yet installed.

Scope of delivery	: Galvanised plate. HDPE socket with SBR seal. Flange and EPDM seal.
Application	: Warm roof (Metalleichtbau) and applications acc. to DIN 18234.
Connection pipe system	: Electrofusion coupler d90 mm Code 410995. Ring groove for snap socket d90 mm Code 400930.
Outlet	: $d_1 = 90$ mm.
Drilling core size	: $\varnothing \square 180$ mm.
Material	: HDPE, galvanised steel, stainless steel, SBR, EPDM.

n = number of bolts
M = thread

Akasison XL90 reinforcement plate with vapour barrier connection and fire protection

according to DIN 18234 to 18807
SBR and EPDM seal

HDPE/intumescent material/
galvanised steel/stainless steel

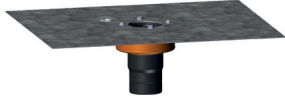

d ₁	Code	D	H
90	749722	4	8

Akasison XL90 reinforcement plate according to DIN 18807 for the vapour barrier connection and fire collar according to 18234 in siphonic roof drainage systems. Applied in insulated metal roofs in combination with roof outlet Akasison XL90. At the top of the metal plate a vapour barrier foil or bitumen can be applied. In combination with specific roofs, the metal plate can be used as reinforcing plate. The HDPE socket can be connected for pre-completion building drainage when insulation and roof outlets are not yet installed.

Scope of delivery	: Galvanised plate incl. Akasison fire collar. HDPE socket with SBR seal. Flange and EPDM seal.
Application	: Warm roof (Metalleichtbau) and applications acc. to DIN 18234.
Connection pipe system	: Electrofusion coupler d90 mm Code 410995. Ring groove for snap socket d90 mm Code 400930.
Outlet	: d ₁ = 90 mm.
Drilling core size	: Ø □ 180 mm.
Material	: HDPE, galvanised steel, stainless steel, SBR, EPDM.

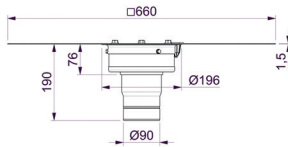

n = number of bolts
M = thread

Air baffle with integrated leafguard Ø 250 mm

ASA

Including fixing bolts.

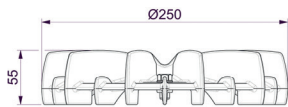

d ₁	Code		
250	747550		

Air baffle for base outlet for siphonic roof drainage systems.
According to EN1253, tested by TÜV.
Air baffle for base outlet for siphonic roof drainage systems.

Scope of delivery : Akasison air baffle Ø 250 mm
: With connection to base roof outlet (roof/gutter outlet is not included).

Application : Akasison roof outlets

Performance at 55mm : With Akasison XL75 base outlet 1-20,0 l/s.
: With Akasison XL90 base outlet 1-21,5 l/s.
: Combination with base outlet tested and approved to EN1253.

Material : ASA (UV-stabilized).

Air baffle with integrated leafguard 420

ASA

Including fixing bolts.

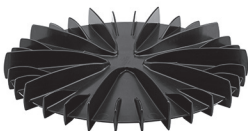

d ₁	Code		
420	749053		

Air baffle for base outlet for siphonic roof drainage systems.
According to EN1253, tested by TÜV.
For application in combination with Akasison XL75 and XL90 base outlet.

Scope of delivery : Akasison air baffle Ø 420 mm
: With connection to base roof outlet (roof/gutter outlet is not included).

Application : Akasison roof outlets

Performance at 55mm : With Akasison XL75 base outlet 1-24,5 l/s.
: With Akasison XL90 base outlet 1-35,9 l/s.
: Combination with base outlet tested and approved to EN1253.

Material : ASA (UV-stabilized).

Air baffle with integrated leafguard height adjustable emergency overflow XL75

ASA

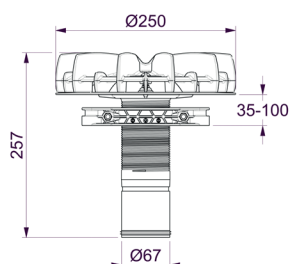

d ₁	Code	Description
75	747551	Air baffle Ø 250 mm

Air baffle for base outlet for emergency overflow siphonic roof drainage systems. According to EN1253, tested by TÜV. For application in combination with Akasison XL75 base outlet.

Performance at 55mm : With Akasison XL75 base outlet 1-22,5 l/s.
Combination with base outlet tested and approved to EN1253.

Material : ASA (UV-stabilized).

Height adjustable : 35-100 mm.

Separate seal : Code 745803

Air baffle with integrated leafguard height adjustable emergency overflow XL90

ASA

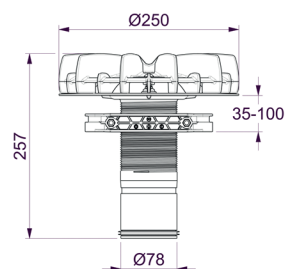

d ₁	Code	Description
90	749051	Air baffle Ø 250 mm

Air baffle for base outlet for emergency overflow siphonic roof drainage systems. According to EN1253, tested by TÜV. For application in combination with Akasison XL90 base outlet.

Performance at 55mm : With Akasison XL90 base outlet 1-27,4 l/s.
Combination with base outlet tested and approved to EN1253.

Material : ASA (UV-stabilized).

Height adjustable : 35-100 mm.

Air baffle Airlock with integrated leafguard height adjustable emergency overflow XL75

ASA

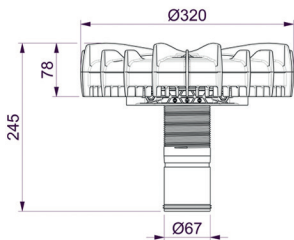

d ₁	Code	Description
75	747554	Airlock Ø 320 mm

Air baffle for base outlet for emergency overflow siphonic roof drainage systems. According to EN1253, tested by TÜV. For application in combination with Akasison XL75 base outlet.

Performance at 55mm : 1-21,4 l/s.
Combination with base outlet tested and approved to EN1253.

Material : ASA (UV-stabilized).
Height adjustable : 35-100 mm.
Separate seal : Code 745803

Air baffle Airlock with integrated leafguard height adjustable emergency overflow XL90

ASA

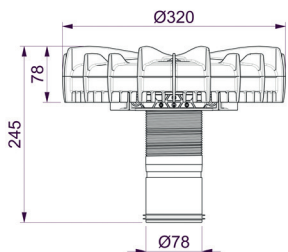

d ₁	Code	Description
90	749054	Airlock Ø 320 mm

Air baffle for base outlet for emergency overflow siphonic roof drainage systems. According to EN1253, tested by TÜV. For application in combination with Akasison XL90 base outlet.

Performance at 55mm : With Akasison XL90 base outlet 1-29,2 l/s.
Combination with base outlet tested and approved to EN1253.

Material : ASA (UV-stabilized).
Height adjustable : 35-100 mm.

Air baffle with integrated leafguard emergency overflow

ASA



d ₁	Code		
250	747552		

Air baffle for base outlet for emergency overflow siphonic roof drainage systems. According to EN1253, tested by TÜV. For application in combination with Akasison XL75 and XL90 base outlet.

Scope of delivery	: Akasison air baffle Ø 250 mm : With emergency fixed ring, EPDM seal and fixation extension set of 2.
Performance at 55 mm	: With Akasison XL75 base outlet 1-22,4 l/s. : With Akasison XL90 base outlet 1-26,8 l/s.
Material	: Combination with base outlet tested and approved to EN1253. : ASA (UV-stabilized), EPDM, stainless steel

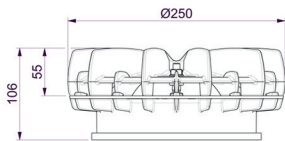

Roof outlet XL75 for metal gutter

with 75 mm connection

HDPE/ASA/stainless steel

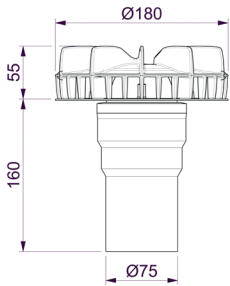

d ₁	Code		Type	Description
75	747800		Akasison XL75 MET	Metal gutter
75	747802	1)	Akasison XL75 COV MET	Metal gutter with covering

1) with EPDM flange for installation covered gutter

Roof outlet for gutter flange for siphonic roof drainage systems.
According to EN1253, tested by TÜV.
With holes for application in metal gutter.

Scope of delivery : Air baffle with integrated leafguard (UV-stabilized).
Connection to HDPE.

Application : Gutter.
Insulation thickness : n.a.
Emergency overflow : Code 747591, 747592.
Connection to HDPE : Electrofusion coupler d75 mm Code 410795.
Dimensions : d₁ = 75 mm.
Drilling core size : Ø □ 110 mm.
Performance : 1-22,9 l/s at 55mm.
Material : ASA, stainless steel, HDPE.

Roof outlet XL75 for metal gutter clamp flange

with 75 mm connection

HDPE/ASA/stainless steel

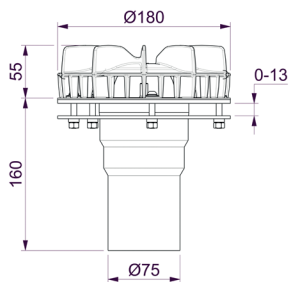

d ₁	Code		Type	Description
75	747808		Akasison XL75 MET Clamp	Metal gutter

Roof outlet with clamp flange for gutter for siphonic roof drainage systems.
According to EN1253, tested by TÜV.
With holes for application in metal gutter.

Scope of delivery : Air baffle with integrated leafguard (UV-stabilized).
Clamp flange with prefixed seal.
Connection to HDPE.

Application : Gutter.
Insulation thickness : n.a.
Emergency overflow : Code 747591, 747592.
Connection to HDPE : Electrofusion coupler d75 mm Code 410795.
Dimensions : d₁ = 75 mm.
Drilling core size : Ø □ 110 mm.
Performance : 1-22,9 l/s at 55mm.
Material : ASA, stainless steel, EPDM, HDPE.

Roof outlet XL90 for metal gutter

with 90 mm connection

HDPE/ASA/stainless steel

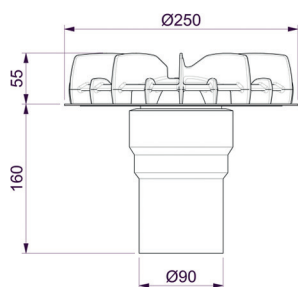

d ₁	Code	Type	Description
90	749800	Akasison XL90 MET	Metal gutter

Roof outlet for gutter for siphonic roof drainage systems.
According to EN1253, tested by TÜV.
With holes for application in metal gutter.

Scope of delivery	: Air baffle with integrated leafguard (UV-stabilized). Connection to HDPE.
Application	: Gutter.
Insulation thickness	: n.a.
Emergency overflow	: Code 749051, 749054, 747552, 747590.
Connection to HDPE	: Electrofusion coupler d90 mm Code 410995.
Drilling core size	: Ø □ 130 mm.
Performance	: 1-21,5 l/s at 55mm. 1-32,6 l/s at 70 mm.
Material	: ASA, stainless steel, HDPE.

Roof outlet XL90 clamp flange for metal gutter

with 90 mm connection

HDPE/ASA/stainless steel

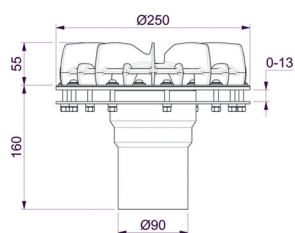

d ₁	Code	Type	Description
90	749808	Akasison XL90 MET Clamp	Metal gutter

Roof outlet with clamp flange for gutter for siphonic roof drainage systems.
According to EN1253, tested by TÜV.
With holes for application in metal gutter.

Scope of delivery	: Air baffle with integrated leafguard (UV-stabilized). Clamp flange with prefixed seal. Connection to HDPE. Nuts and bolts.
Application	: Gutter.
Insulation thickness	: n.a.
Emergency overflow	: Code 749051, 749054, 747552, 747590.
Connection to HDPE	: Electrofusion coupler d90 mm Code 410995.
Dimensions	: d ₁ = 90 mm.
Drilling core size	: Ø □ 130 mm.
Performance	: 1-21,5 l/s at 55mm. 1-32,6 l/s at 70 mm.
Material	: ASA, stainless steel, HDPE.

Roof outlet XL75 for concrete gutter

with 75 mm connection

HDPE/ASA/stainless steel

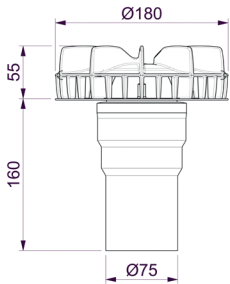

d ₁	Code		Type	Description
75	747801		Akasion XL75 CON	Concrete gutter
75	747803	1)	Akasion XL75 COV CON	Concrete gutter with covering

1) with flange for installation covered gutter

Roof outlet for gutter for siphonic roof drainage systems.
According to EN1253, tested by TÜV.
Gutter outlet with holes for application in concrete gutter.

Scope of delivery : Air baffle with integrated leafguard (UV-stabilized).
Knock-in bolts for installation concrete gutter.

Application : Gutter.
Insulation thickness : n.a.
Emergency overflow : Code 747591, 747592.
Connection to HDPE : Electrofusion coupler d75 mm Code 410795.
Drilling core size : Ø □ 110 mm.
Performance : 1-22,9 l/s at 55mm.
Material : ASA, stainless steel, HDPE.

Roof outlet XL90 for concrete gutter

with 90 mm connection

HDPE/ASA/stainless steel

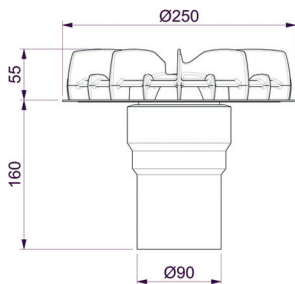

d ₁	Code		Type	Description
90	749801		Akasion XL90 CON	Concrete gutter

Roof outlet for gutter for siphonic roof drainage systems.
According to EN1253, tested by TÜV.
Gutter outlet with holes for application in concrete gutter.

Scope of delivery : Air baffle with integrated leafguard (UV-stabilized).
Knock-in bolts for installation concrete gutter.

Application : Gutter.
Insulation thickness : n.a.
Emergency overflow : Code 749051, 749054, 747552, 747590.
Connection to HDPE : Electrofusion coupler d90 mm Code 410995.
Drilling core size : Ø □ 130 mm.
Performance : 1-21,5 l/s at 55mm.
1-32,6 l/s at 70 mm.
Material : ASA, stainless steel, HDPE.

Emergency overflow (low) for gutter outlet XL75

ASA/stainless steel

EPDM seal

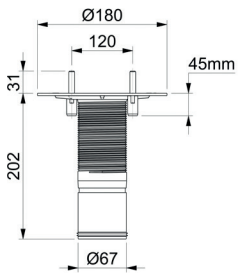
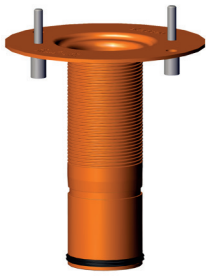

d_1	Code	n	M
67	747591	2	8

The emergency overflow set can be applied in combination with Akasison gutter outlets XL75.

Scope of delivery	: Emergency overflow flange. EPDM seal. Air baffle and leaf guard fixation extension (set of 2).
Height raising element	: 45 mm
Application	: Emergency overflow system.
Material	: ASA, EPDM, stainless steel.

n = number of bolts
M = thread

Emergency overflow (high) for gutter outlet XL75

ASA/stainless steel

EPDM seal

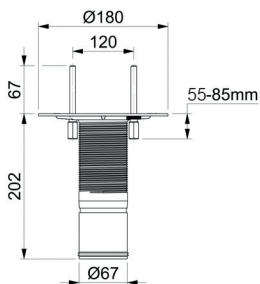
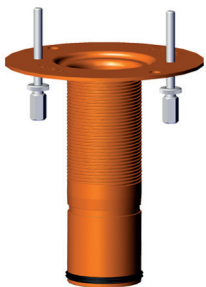

d_1	Code	n	M
67	747592	2	8

The emergency overflow set can be applied in combination with Akasison gutter outlets XL75. This emergency ring places the air baffle 45mm above the roof surface. Two threaded ends with sockets are included to secure the air baffle to the roof outlet.

Scope of delivery	: Emergency overflow flange. EPDM seal. Air baffle and leaf guard fixation extension (set of 2).
Height raising element	: 60-85 mm
Application	: Emergency overflow system.
Material	: ASA, EPDM, stainless steel.

n = number of bolts
M = thread

Rail

Galvanised steel

Rail length = 5 m



	Code	B	D	G	R
	700005	30	30	14,5	2
	700007	41	41	14,5	2

Application

: Code 700005 for brackets 40 to 200 mm.
Code 700007 for brackets 250 and 315 mm.

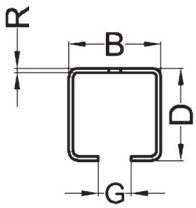

Rail connector

Galvanised steel

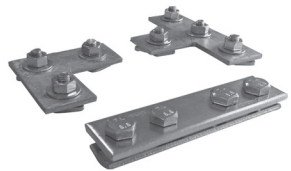

	Code	Type
	700015	straight
	700016	L-angle
	700017	T-angle

Bolts M10.

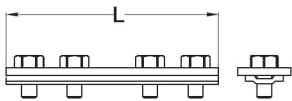

Rail suspension

Galvanised steel

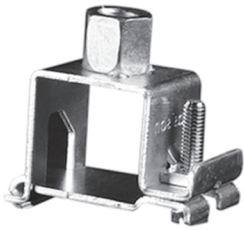

	Code	l_1	l_2	R
	700025	30	30	M10
	700027	41	41	M10

Application : Code 700025 for rail 30 x 30 mm (Code 700005).
Code 700027 for rail 41 x 41 mm (Code 700007).

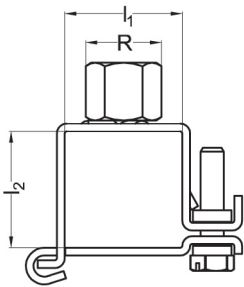

Rail bracket

Galvanised steel



d_1	Code	d_2	l_1	l_2	l_4	R
40	750435	42	35	30	30	M10
50	750535	52	35	30	30	M10
56	755635	58	35	30	30	M10
63	750635	65	35	30	30	M10
75	750735	77	35	30	30	M10
90	750935	92	35	30	30	M10
110	751135	112	35	30	30	M10
125	751235	127	35	30	30	M10
160	751635	162	35	30	30	M10
200	752035	202	35	30	30	M10
250	752535	252	35	41	40	M10
315	753135	317	35	41	40	M10

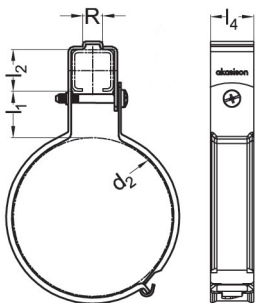

Anchor point set

Galvanised steel



	Code		l_4	R
	730025		21	M10
	730027		40	M10

Application for anchor point d200, 250 and 315 mm.
Includes 2 M10 bolts.

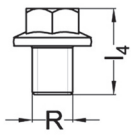

Guide bracket

Galvanised steel



d_1	Code		a	b	s	R
40	700478		93	30	3	1/2"
50	700578		104	30	3	1/2"
56	705678		113	30	3	1/2"
63	700678		113	30	3	1/2"
75	700778		126	30	3	1/2"
90	700978		143	30	3	1/2"
110	701178		161	30	3	1/2"
125	701278		178	30	3	1/2"
160	701678		215	30	3	1/2"
200	702080		283	40	4	1"
250	702580		333	40	4	1"
315	703180		398	40	4	1"

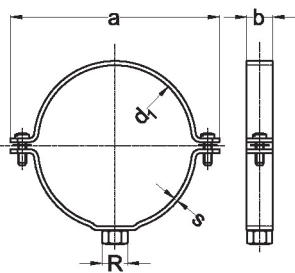

Fully welded.
Thread R 1/2" = 20,5 mm, R1" = 33 mm.

Mounting plate for guide bracket

Galvanised steel



	Code	R
	709478	1/2"
	709480	1"

Fully welded.
 Thread R 1/2" = 20,5 mm, R1" = 33 mm.

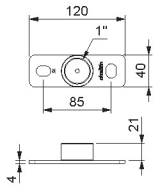
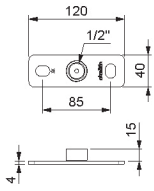

Pipe

Pipe length = 5 m

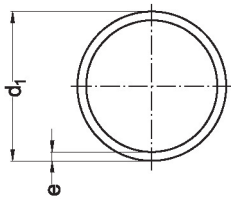

d_1	Code	S	e	A (cm ²)	kg/m	
40	100400	12,5	26	3	9,1	0,36
50	100500	12,5	26	3	15,2	0,45
56	105600	12,5	26	3	19,6	0,51
63	100600	12,5	26	3	25,5	0,58
75	100700	12,5	26	3	37,4	0,7
90	100900	12,5	26	3,5	54,1	0,98
110	101100	12,5	26	4,2	80,7	1,43
125	101200	12,5	26	4,8	104,2	1,85
160	101600	12,5	26	6,2	171,1	3,04
200	102010	12,5	26	7,7	267,6	4,69
250	102510	12,5	26	9,6	418,4	7,3
315	103110	12,5	26	12,1	664,2	11,6

Drainage pipe d40-315 mm according to EN 1519 for application in buildings, d110-315 mm for buried pipe application according EN 12666.

S= pipe class.

A (cm²) = cross sectional area of flow.

Reducer eccentric

HDPE

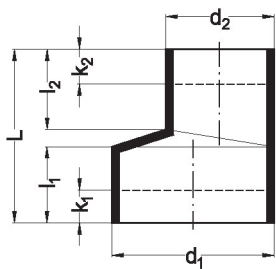

d_1/d_2	Code	L	l_1	l_2	k_1	k_2
50/40	160504	80	35	37	20	20
56/40	165604	80	35	37	20	20
56/50	165605	80	35	37	20	20
63/40	160604	80	35	37	20	20
63/50	160605	80	35	37	20	20
63/56	160656	80	35	37	20	20
75/40	160704	80	35	30	20	20
75/50	160705	80	35	37	20	20
75/56	160756	80	35	37	20	20
75/63	160706	80	35	37	20	20
90/40	160904	80	30	33	20	20
90/50	160905	80	30	34	20	20
90/56	160956	80	30	36	20	20
90/63	160906	80	30	39	20	20
90/75	160907	80	30	44	20	20
110/40	161104	80	31	34	20	20
110/50	161105	80	31	34	20	20
110/56	161156	80	31	35	20	20
110/63	161106	80	31	34	20	20
110/75	161107	80	31	36	20	20
110/90	161109	80	31	41	20	20
125/56	161256	80	35	37	20	20
125/63	161206	80	35	37	20	20
125/75	161207	80	35	30	20	20
125/90	161209	80	35	32	20	20
125/110	161211	80	36	36	20	20
160/110	161611	80	28	36	20	20
160/125	161612	80	32	36	20	20

Reducer eccentric long

HDPE



d_1/d_2	Code	Type	L	l_1	l_2	l_3	l_4	d_3	k_1	k_2
200/110	142011	A	335	95	36	165	55	160	75	20
200/125	142012	A	335	95	36	165	55	160	75	20
200/160	142016	B	260	95	95	-	-	-	75	75
250/200	142520	B	290	105	95	-	-	-	85	75
315/200	143120	B	340	115	95	-	-	-	95	75
315/250	143125	B	340	115	95	-	-	-	85	75

A

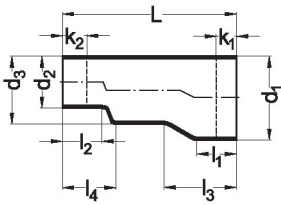

B

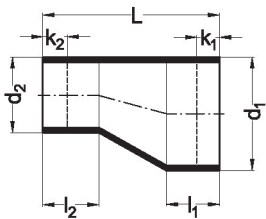

Elbow 88,5°

HDPE

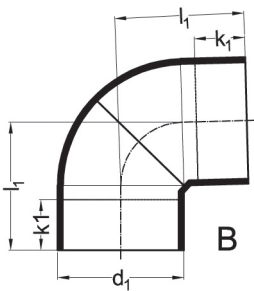
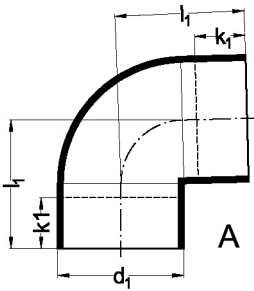

d_1	Code		Type	l_1	k_1
40	120488		A	55	25
50	120588		A	60	20
56	125688		A	65	20
63	120688		A	70	20
75	120788		A	75	20
90	120988		A	80	20
110	121188		A	95	25
125	121288		A	100	25
160	121688		A	120	25
200	122088	1)	B	290	60
250	122588	2)	8	350	60
315	123188	2)	B	360	60

1) fabricated

2) fabricated - wall thickness e according to S12,5

Elbow 45°

HDPE

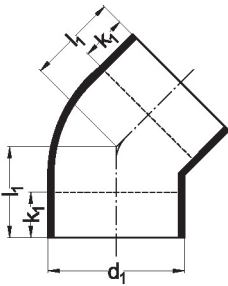

d_1	Code		l_1	k_1
40	120445		40	20
50	120545		45	20
56	125645		45	20
63	120645		50	20
75	120745		50	20
90	120945		55	20
110	121145		60	25
125	121245		65	25
160	121645		69	20
200	122045		173	60
250	122545	1)	182	60
315	123145	1)	195	60

1) wall thickness e according to S12,5

Elbow 45° with long side

HDPE

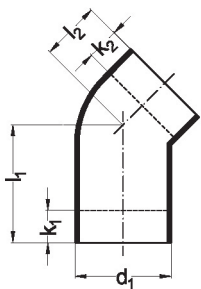

d_1	Code		l_1	l_2	k_1	k_2
75	120746		145	50	120	25
90	120946		150	55	120	25
110	121146		147	60	120	25

Elbows 45° with long side are applied for making the transition from stack to building drain acc. to EN 12056 (see drawing).

1 stack
2 building drain

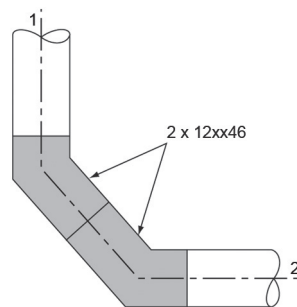

Y-branch 45°

HDPE

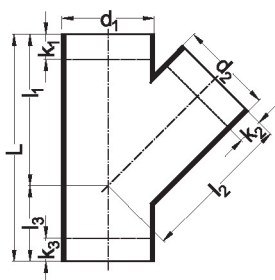

d_1/d_2	Code		L	l_1/l_2	l_3	k_1	k_2	k_3
40/40	300404		135	90	45	30	30	25
50/40	300504		165	110	55	45	45	40
50/50	300505		165	110	55	20	20	35
56/40	305604		180	120	60	35	30	60
56/50	305605		180	120	60	30	30	40
56/56	305656		180	120	60	25	25	40
63/40	300604		195	130	65	40	45	45
63/50	300605		195	130	65	30	30	50
63/56	300656		195	130	65	25	25	45
63/63	300606		195	130	65	20	20	40
75/40	300704		210	140	70	60	50	65
75/50	300705		210	140	70	40	30	70
75/56	300756		210	140	70	35	25	55
75/63	300706		210	140	70	35	25	45
75/75	300707		210	140	70	25	25	40
90/40	300904		240	160	80	65	55	75
90/50	300905		240	160	80	50	40	80
90/56	300956		240	160	80	45	35	75
90/63	300906		240	160	80	40	30	70
90/75	300907		240	160	80	35	30	65
90/90	300909		240	160	80	20	20	50
110/40	301104		270	180	90	75	60	95
110/50	301105		270	180	90	55	50	95
110/56	301156		270	180	90	45	40	90
110/63	301106		270	180	90	40	35	85
110/75	301107		270	180	90	35	30	75
110/90	301109		270	180	90	30	25	65
110/110	301111		270	180	90	20	20	55
125/50	301205		300	200	100	115	60	75
125/56	301256		300	200	100	110	50	45
125/63	301206		300	200	100	60	45	105
125/75	301207		300	200	100	50	40	95
125/90	301209		300	200	100	35	30	30
125/110	301211		300	200	100	25	25	25
125/125	301212		300	200	100	20	20	20
160/50	301605	¹⁾	375	250	125	120	115	65
160/56	301656	¹⁾	375	250	125	120	115	65
160/63	301606	¹⁾	375	250	125	120	115	65
160/75	301607		375	250	125	120	115	65
160/90	301609		375	250	125	110	105	55
160/110	301611		375	250	125	50	40	45
160/125	301612		375	250	125	10	20	40
160/160	301616		375	250	125	10	15	25
200/50	302005	²⁾	540	360	180	95	15	175
200/56	302056	²⁾	540	360	180	95	15	175
200/63	302006	²⁾	540	360	180	95	15	175
200/75	302007	³⁾	540	360	180	95	160	175
200/90	302009	³⁾	540	360	180	80	150	165
200/110	302011	³⁾	540	360	180	65	140	150
200/125	302012	³⁾	540	360	180	55	130	140
200/160	302016	³⁾	540	360	180	35	85	115

¹⁾ fabricated²⁾ fabricated from branch 200/75 mm with concentric reducer³⁾ wall thickness e according to S12,5

-- to be continued --

d_1/d_2	Code		L	l_1/l_2	l_3	k_1	k_2	k_3
200/200	302020	3)	555	375	180	0	0	95
250/75	302507	1)	660	440	220	170	205	235
250/90	302509	1)	660	440	220	160	195	225
250/110	302511	1)	660	440	220	150	185	215
250/125	302512	1)	660	440	220	140	175	205
250/160	302516	1)	660	440	220	120	130	180
250/200	302520	1)	660	440	220	90	50	150
250/250	302525	1)	900	600	300	160	160	250
315/75	303107	1)	840	560	280	255	280	325
315/90	303109	1)	840	560	280	245	270	315
315/110	303111	1)	840	560	280	235	260	305
315/125	303112	1)	840	560	280	220	250	290
315/160	303116	1)	840	560	280	200	205	270
315/200	303120	1)	840	560	280	175	125	240
315/250	303125	1)	840	560	280	140	130	205
315/315	303131	1)	950	610	340	170	170	280

1) fabricated

2) fabricated from branch 200/75 mm with concentric reducer

3) wall thickness e according to S12,5

Clean out branch 90°

HDPE

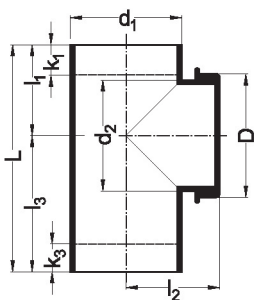

d_1/d_2	Code		D	L	l_1	l_2	l_3	k_1	k_3
40/40	230400		64	130	55	80	75	25	45
50/50	230500		72	150	60	72	90	25	55
56/56	235600		83	175	70	100	105	30	65
63/63	230600		87	175	70	100	105	30	60
75/75	230700		91	175	70	100	105	25	55
90/90	230900		118	200	80	100	120	25	70
110/110	231120		127	225	90	105	135	20	65
125/110	231200		140	250	100	123	150	20	80
160/110	231620		134	350	140	120	210	60	135
200/110	232000		140	360	180	160	180	90	90
250/110	232500		140	440	220	185	220	110	110
315/110	233100		140	560	280	220	280	170	170

Clean out branches 90° can be applied in horizontal and vertical pipes.

Electrofusion coupler

HDPE

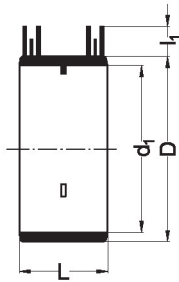

d_1	Code	D	L	I_1	System
40	410495	52	54	16	5A/80s
50	410595	62	54	16	5A/80s
56	415695	68	54	16	5A/80s
63	410695	75	54	16	5A/80s
75	410795	87	54	16	5A/80s
90	410995	102	56	16	5A/80s
110	411195	123	60	16	5A/80s
125	411295	137	66	16	5A/80s
160	411695	172	73	14	5A/80s
200	412065	233	175	21	220V/420s
250	412565	283	175	22	220V/420s
315	413165	349	175	22	220V/420s

The electrofusion couplers are delivered with centre stops. These stops can easily be removed with a knife or screwdriver (200, 250, 315), so that the coupler can be used as a slide-coupler. Before welding, cut pipe ends squarely with a pipe cutting tool, remove the oxide film with a scraper and mark the insertion depth. The couplers can easily be welded with our Akatherm control box and other suitable control boxes.

Expansion socket with anchor point

with protection plug
SBR seal

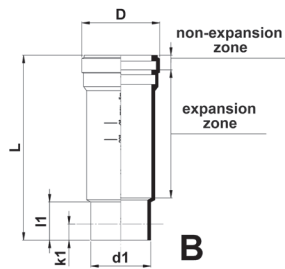
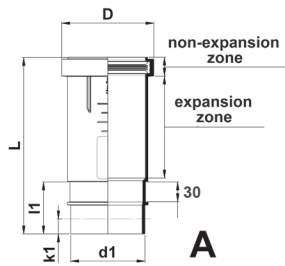

d_1	Code		Type	D	L	Non-expansion zone	Expansion zone	I_1	k_1
40	400420		B	56	172	25	109	35	-
50	400520		B	65	172	25	109	35	-
56	405620		B	72	172	25	109	35	-
63	400620	¹⁾	B	80	155	25	114	15	-
75	420720		A	98	255	32	148	72	30
90	420920		A	114	255	32	148	72	30
110	421120		A	135	260	35	145	76	35
125	421220		A	152	260	38	142	76	35
160	421620		A	186	266	41	148	76	35
200	402020	²⁾	B	240	300	45	200	55	-
200	422020		A	240	435	45	200	180	50
250	402520	²⁾	B	298	300	45	205	55	-
250	422520		A	298	460	55	205	200	100
315	403120	²⁾	B	372	355	55	225	68	-
315	423120		A	372	495	55	205	235	120

¹⁾ butt-weld only

²⁾ without protection plug - butt-weld only

1 sealing ring

The expansion sockets can absorb length changes of pipes with a max. length of 6 m. A temperature difference of 10°C will result in expansion or contraction of 8 mm. The insertion depths at ambient temperature of 0°C and 20°C are indicated on the sockets.

Expansion sockets d_{75} -315 mm of type A have an integrated anchor point, that is able to incorporate extension of the 5 meter down pipe.

Electrofusion control box CB160-U



d ₁	Code	Dim.	V~	Hz	kg	A max	W max
40-160	419830	65x200x85	230	50/60	1,7	5	1150

The Akatherm CB160-U control box is suitable for welding electrofusion couplers from d = 40-160 mm.

Electrofusion control box CB315-U



d ₁	Code	Dim.	V~	Hz	kg	A max	W max
40-315	419910	440x220x180	230	50/60	5	10,9	2500

The Akatherm CB315-U control box is suitable for welding electrofusion couplers from d = 40-160 mm (with yellow cable) and electrofusion couplers from d = 200-315 mm (with blue cable). Yellow and blue output leads and hand scraper are supplied as standard with control box Code 419910.

Output leads for control box CB315-U

4 pins



d ₁	Code	System	Colour
40-160	419971	5A/80s	yellow
200-315	419972	220V/420s	blue

Weld extension cable



d ₁	Code		Colour
40-315	419975		black

Connection cable USB

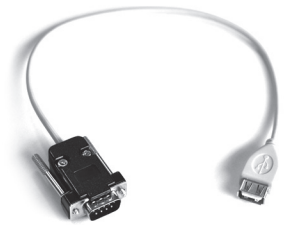

	Code		Colour
	419977		grey

Scraper Spider



	Code		L	B	H	kg
	419860	1)	105	80	60	0,460
	419865	2)	260	210	80	1,600
	419869	3)	260	210	80	1,600

1) excluding Spider accessories

2) including Spider accessories case, rattle, extension for rattle and blades for replacement

3) including Spider and accessories case

Rotation scraper, for the quick removal of the oxide layer of PE pipes and fittings d50-125 mm.

Spider accessories

Code	Accessories
419861	Replacement blades
419862	Roller set 3x
419863	Roller holder
419864	Replacement screw M2, 5x6 for blades
419866	Case

Scraper FWSG 225

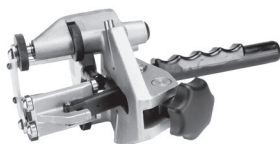

Code	Type	Diameters
613409	Rotation	75-225mm

Rotation scraper for the complete removal of the oxidic layer of PE pipes and fittings d75-225 mm. The scraper is delivered in a useful aluminium transportation case, and includes a set of spare blades.

Manual scraper



Code	
419600	
419601	replacement blade

PE cleaner



	Code	
	601000	

Reclosable container with 100 cleaning cloths.

Properties:

- Powerful cleaning properties
- Rapid and complete vaporization
- Lint-Free
- Wipe size 150 x 195 mm
- one-time use

For cleaning and degreasing pipes, sockets and fittings of PE
Wipes impregnated with ethanol (very high purity, min. 99%)

Grease pencil

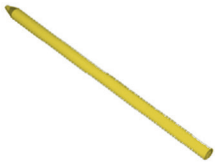

	Code		Description
	419620		PE marker

Package with 12 pencils.

Butt-welding machine 160C



d_1	Code	L	B	H	kg
40-160	492000				

d_1 = 40-50-63-75-90-110-125-160.
Suitable for welding Y-branches 45°.

Butt-welding machine 250 C



d_1	Code	L	B	H	kg
75-250	493000				

d_1 = 75-90-110-125-160-200-250.
Suitable for welding Y-branches 45°.

Butt-welding machine 315 C



d_1	Code	L	B	H	kg
90-315	494000				

d_1 = 90-110-125-160-200-250-315.
Suitable for welding Y-branches 45°.

Fixing nuts for Akasion leaf guard (set of 2)

Stainless steel



	Code	Description
	745551	M8 stainless steel

Fixing nuts for Akasion clamp flange (set of 6)

Stainless steel



	Code	Description
	745562	M8 flange Nut, stainless steel AISI 304 (A2)

Fixing nuts for Akasion emergency overflow (set of 2)

Stainless steel



	Code	Description
	745582	M8 x 40

Fixing nuts for reinforcement plate Akasion XL75 (set of 4)

Stainless steel



	Code	Description
	745723	M8 flange Nut, stainless steel AISI 304 (A2)

Emergency overflow set for Akasion XL75 and XL90

ASA/stainless steel

EPDM seal



d ₁	Code	n	M
195	747590	2	8

The emergency overflow set can be applied in combination with Akasion roof outlets XL75 and XL90. To be combined with air baffle Ø 250 mm.

- Scope of delivery : Emergency overflow flange.
EPDM seal.
- Application : Air baffle and leaf guard fixation extension (set of 2).
- Material : Emergency overflow system.
: ASA, EPDM, stainless steel.

n = number of bolts
M = thread

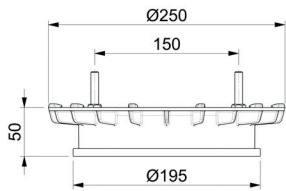

Clamp flange Akasion

Stainless steel



	Code	Description
	745566	253 x 118 x 10mm. stainless steel AISI 304 (A2)

For roof outlets Akasion Code 747540, 747541, 747580, 747581, 749040 and 749041.
Without fixing nuts.

Seal for clamp flange Akasion

EPDM

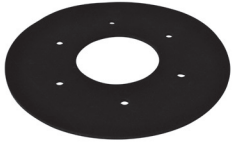

Code	Description
745565	250 x 110 x 4 mm EPDM

For roof outlets Akasion Code 747540, 747541, 747580, 747581, 749040, 749041.

Heating element 230V/7W Akasion



Code	V	Watt
745540	230	7

For roof outlets Akasion XL75.
Self regulation heating element.
Direct connection to 230 V.
Including 1 m cable.

Fire protective collar Akasion



Code	Description
747733	for XL75
749733	for XL90

Metal body with intumescent material.
3-point fastening.

EPS insulation block

EPS

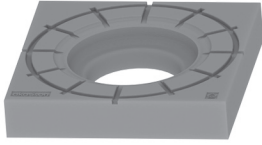

	Code	
	745533	

For Akasison roof outlets XL75.
Flame-retardant, silver grey with reduced thermal conductivity.
Fire behavior EN 13501-1 class E.

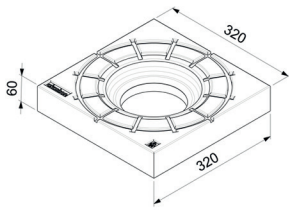
**Temporary foam waterstop**

EPS

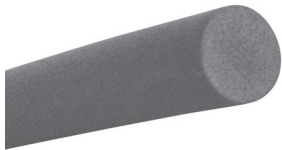

	Code	
	745564	

For d75 mm outlets, reinforcement plates and installation sockets.
Thermoplastic elastomer foam.

Appendix A: Welding parameters

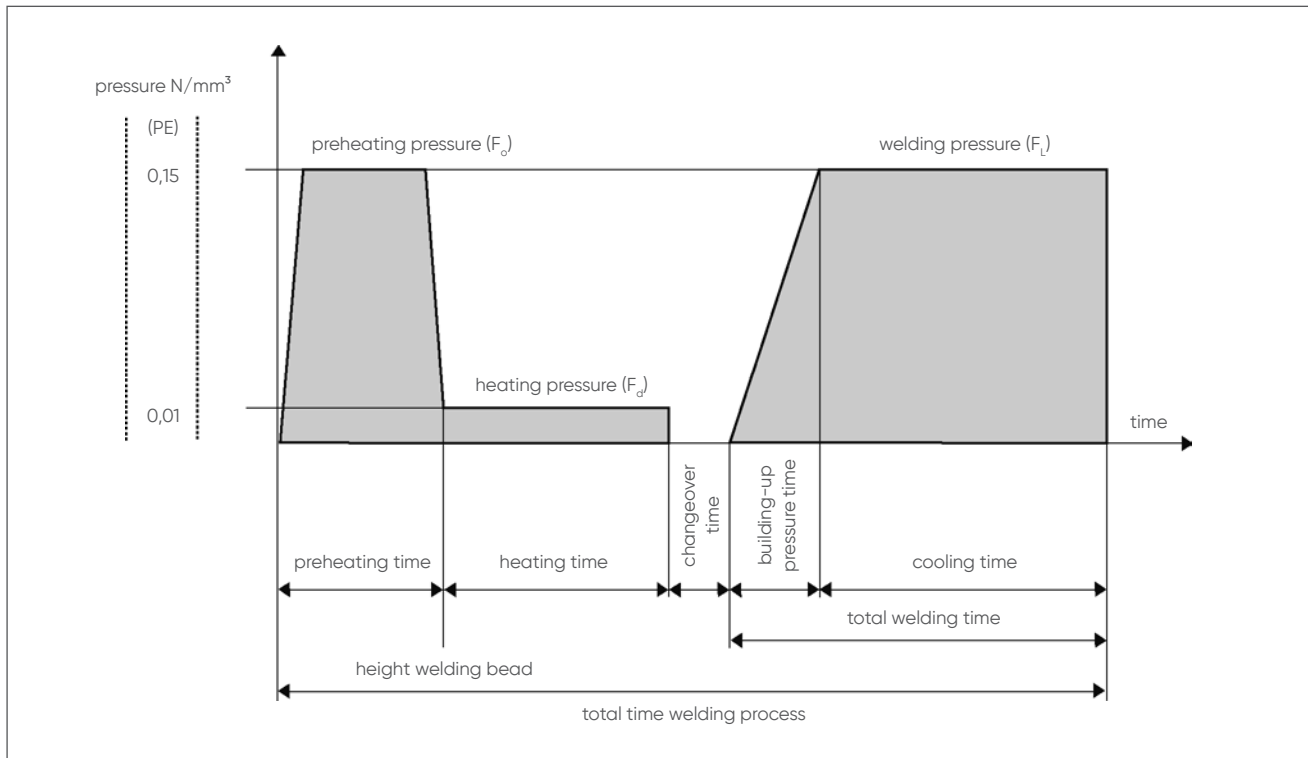

Diameter	Wall thickness	Preheating pressure/ welding pressure (0,15 N/mm ³)	Heating pressure (0,01 N/mm ³)	Height welding bead	Heating time	Changeover time	Building-up pressure time	Cooling time
d ₁	e	F _o /F _L	F _d	mm	sec.	sec.	sec.	min.
mm	mm	N	N					
40	3,0	55	4	0,5	29	4	4	4
50	3,0	70	5	0,5	30	4	4	4
56	3,0	75	5	0,5	30	4	4	4
63	3,0	85	6	0,5	31	4	4	4
75	3,0	105	7	0,5	32	5	5	4
90	3,5	145	10	0,5	35	5	5	4
110	4,2	210	14	0,5	42	5	5	6
125	4,8	275	18	1,0	48	5	5	6
160	6,2	450	30	1,0	62	6	6	9
110	3,4	175	12	0,5	35	5	5	4
125	3,9	225	15	0,5	39	5	5	5
160	4,9	370	25	1,0	49	5	5	7
200	6,2	570	38	1,0	62	6	6	9
250	7,8	900	60	1,5	77	6	6	11
315	9,7	1400	93	1,5	77	6	6	11
200	7,7	700	47	1,5	77	6	6	11
250	9,6	1090	73	1,5	97	7	7	13
315	12,1	1730	115	2,0	121	6	8	16

Welding parameters Akatherm HDPE drainage

In the table above the welding parameters can be found for Akatherm HDPE. The exact regulation of the welding machine depends on its mechanical resistance. The tables provided with the machine are to be used for regulating the machine.

Appendix B: Commissioning Akasison

Objective: Ensure the installed Akasison siphonic roof drainage system is clean, correctly assembled, and functions as designed. The following commissioning checks must be completed (based on the Akasison XL Specification Manual guidelines for HDPE or Akasison L specification manual for TPHP):

- **Roof surface cleaned:** Verify the roof catchment area is free of all debris, packaging, and insulation off-cuts before testing. Any material left on the roof could wash into outlets and cause blockages.
- **Pipework flushed:** Ensure **all siphonic rainwater pipes are flushed through with water** to remove installation debris (dirt, plastic shavings, etc.). Flushing cleans the system and helps reveal any leaks early.
- **Outlet assembly check:** Inspect every Akasison **roof outlet to confirm proper assembly**. All components (clamping ring, **air baffle/anti-vortex insert**) must be correctly installed and secure. This guarantees that air will not be sucked into the system during operation.
- **Supports & fixings:** Perform a visual check that **rails, rails suspensions and brackets are installed per design**, with the correct spacing and quantity. All support clamps should be tight and in the right locations to prevent pipe sagging or movement when the system is in operation.
- **Emergency overflow provision:** Confirm that **emergency overflow outlets are installed as specified in the design** and in all required locations. Verify the arrangement is complete (no planned overflow missing).
- **Emergency outlet height:** **Measure the height of every adjustable emergency overflow outlet** and ensure it matches the level given in the hydraulic design report. Typically, an emergency overflow is set so that it activates only when the primary system capacity is exceeded.
- **Tightness (leak) test:** Conduct a **visual leak check** on all joints and connections by filling the system (or during flushing). No drips or moisture should be observed at connections. Any leaks must be fixed and re-tested to ensure the system is completely watertight under siphonic conditions.
- **Functional test (if possible):** It is recommended to **simulate heavy rainfall** (e.g. using hoses or controlled water fill) to observe the system priming and draining. All outlets should draw water and the downpipes should run full-bore without air sucking/gurgling. (optional but beneficial).
- **Documentation and sign-off:** Record the completion of each commissioning step. It's good practice to use a checklist (date and sign each item) for the project files. Finally, have the responsible engineer or inspector sign off that the Akasison system has been commissioned according to the respective design manual and is ready for service.

By following the above commissioning steps, the Akasison siphonic drainage system will be verified to operate safely and efficiently from day one. Each check is crucial to prevent early-life issues and to guarantee that the system performs to its design capacity, including the critical emergency overflow function.

**Disclaimer Commissioning Akasison*

Akasison is solely responsible for the quality of its products and the design, provided that the design has been prepared by the Akasison Technical Design Office as defined in the documentation and information provided. This commissioning document serves as a checklist for the verification and commissioning process of the Akasison siphonic roof drainage system, in accordance with the relevant specification manuals.

Important:

Akasison does not assume accountability or responsibility for performing the commissioning checks described in this document. The responsibility for carrying out, recording, and signing off on each commissioning step—including cleaning, flushing, assembly verification, support checks, emergency overflow provision, leak testing, and functional testing—rests with the party undertaking the installation or inspection.

Akasison's role is limited to providing guidance and technical documentation to support a correct and safe commissioning process. By using this checklist, the user acknowledges that Akasison's obligations do not extend to the execution or supervision of the commissioning activities, but are confined to the accuracy and completeness of the information and instructions supplied in the documentation.

A

Air baffle Airlock with integrated leafguard height adjustable emergency overflow XL75.....	62
Air baffle Airlock with integrated leafguard height adjustable emergency overflow XL90.....	62
Air baffles.....	60
Air baffle with integrated leafguard 420.....	60
Air baffle with integrated leafguard emergency overflow.....	20
Air baffle with integrated leafguard height adjustable emergency overflow XL75.....	61
Air baffle with integrated leafguard height adjustable emergency overflow XL90.....	61
Air baffle with integrated leafguard Ø 250 mm.....	60
Akasison XL75 installation socket.....	56
Akasison XL75 reinforcement plate without connector.....	57
Akasison XL75 reinforcement plate with vapour barrier connection.....	57
Akasison XL75 reinforcement plate with vapour barrier connection and fire protection.....	58
Akasison XL90 installation socket.....	56
Akasison XL90 reinforcement plate with vapour barrier connection.....	58
Akasison XL90 reinforcement plate with vapour barrier connection and fire protection.....	59
Anchor point set.....	70

70

Base roof outlet XL75 clamp flange.....	54
Base roof outlet XL75 metal for bitumen.....	46
Base roof outlet XL75 PE.....	52
Base roof outlet XL75 PP.....	50
Base roof outlet XL75 PVC.....	48
Base roof outlet XL90 clamp flange.....	54
Base roof outlet XL90 metal for bitumen.....	46
Base roof outlet XL90 PE.....	52
Base roof outlet XL90 PP.....	50
Base roof outlet XL90 PVC.....	48
Brackets Akasison.....	70
Branches.....	77
Butt-welding machine 160C.....	85
Butt-welding machine 250 C.....	85
Butt-welding machine 315 C.....	85
Butt-welding machines.....	85

C

Clamp flange Akasison.....	87
Clean out branch 90°.....	78
Connection cable USB.....	82
Control boxes.....	81

E

Elbow 45°.....	76
Elbow 45° with long side.....	76
Elbow 88,5°.....	75
Elbows.....	75
Electrofusion control box CB160-U.....	81
Electrofusion control box CB315-U.....	81
Electrofusion coupler.....	79
Electrofusion joints.....	79
Emergency overflow.....	67
Emergency overflow (high) for gutter outlet XL75.....	67
Emergency overflow (low) for gutter outlet XL75.....	67
Emergency overflow set for Akasison XL75 and XL90.....	87
EPS insulation block.....	89
Expansion socket with anchor point.....	80

F

Fire protective collar Akasison.....	88
Fixing nuts for Akasison clamp flange (set of 6).....	86
Fixing nuts for Akasison emergency overflow (set of 2).....	86

Fixing nuts for Akasison leaf guard (set of 2).....	86
Fixing nuts for reinforcement plate Akasison XL75 (set of 4).....	87

G

Grease pencil.....	84
Guide bracket.....	70

H

Heating element 230V/7W Akasison.....	88
---------------------------------------	----

I

Installation sockets.....	56
---------------------------	----

M

Manual scraper.....	83
Mounting plate for guide bracket.....	71

O

Output leads for control box CB315-U.....	81
---	----

P

PE cleaner.....	84
Pipe.....	72
Pipes.....	72
Plug-in joints.....	80

R

Rail.....	68
Rail bracket.....	69
Rail connector.....	68
Rails Akasison.....	68
Rail suspension.....	69
Reducer eccentric.....	73
Reducer eccentric long.....	74
Reducers.....	73
Reinforcement plates.....	57
Roof outlets clamp flange.....	54
Roof outlets for gutter.....	64
Roof outlets FPO/TPO - PP.....	50
Roof outlets metal for bitumen.....	46
Roof outlets PE.....	52
Roof outlets PVC.....	48
Roof outlet XL75 for concrete gutter.....	66
Roof outlet XL75 for metal gutter.....	64
Roof outlet XL75 for metal gutter clamp flange.....	64
Roof outlet XL75 HR clamp flange horizontal.....	55
Roof outlet XL75 metal for bitumen horizontal.....	47
Roof outlet XL75 PE horizontal.....	53
Roof outlet XL75 PP horizontal.....	51
Roof outlet XL75 PVC horizontal.....	49
Roof outlet XL90 clamp flange for metal gutter.....	55
Roof outlet XL90 for concrete gutter.....	64
Roof outlet XL90 for metal gutter.....	65

S

Scraper FWSG 225.....	83
Scrapers.....	83
Scraper Spider.....	83
Seal for clamp flange Akasison.....	88
Spare parts Akasison.....	86
Spider accessories.....	83

T

Temporary foam waterstop.....	89
-------------------------------	----

W

Weld extension cable82

Y

Y-branch 45° 77

Art. No.	Page	Art. No.	Page	Art. No.	Page
100400	73	230500	78	303131	78
100500	73	230600	78	305604	77
100600	73	230700	78	305605	77
100700	73	230900	78	305656	77
100900	73	231120	78	400420	80
101100	73	231200	78	400520	80
101200	73	231620	78	400620	80
101600	73	232000	78	402020	80
102010	73	232500	78	402520	80
102510	73	233100	78	403120	80
103110	73	235600	78	405620	80
105600	73	300404	77	410495	79
120445	76	300504	77	410595	79
120488	75	300505	77	410695	79
120545	76	300604	77	410795	79
120588	75	300605	77	410995	79
120645	76	300606	77	411195	79
120688	75	300656	77	411295	79
120745	76	300704	77	411695	79
120746	76	300705	77	412065	79
120788	75	300706	77	412565	79
120945	76	300707	77	413165	79
120946	76	300756	77	415695	79
120988	75	300904	77	419600	83
121145	76	300905	77	419601	83
121146	76	300906	77	419620	84
121188	75	300907	77	419830	81
121245	76	300909	77	419860	83
121288	75	300956	77	419861	83
121645	76	301104	77	419862	83
121688	75	301105	77	419863	83
122045	76	301106	77	419864	83
122088	75	301107	77	419865	83
122545	76	301109	77	419866	83
122588	75	301111	77	419869	83
123145	76	301156	77	419910	81
123188	75	301205	77	419971	81
125645	76	301206	77	419972	81
125688	75	301207	77	419975	81
142011	74	301209	77	419977	81
142012	74	301211	77	420720	80
142016	74	301212	77	420920	80
142520	74	301256	77	421120	80
143120	74	301605	77	421220	80
143125	74	301606	77	421620	80
160504	73	301607	77	422020	80
160604	73	301609	77	422520	80
160605	73	301611	77	423120	80
160656	73	301612	77	492000	85
160704	73	301616	77	493000	85
160705	73	301656	77	494000	85
160706	73	302005	77	601000	84
160756	73	302006	77	613409	83
160904	73	302007	77	700005	68
160905	73	302009	77	700007	68
160906	73	302011	77	700015	68
160907	73	302012	77	700016	68
160956	73	302016	77	700017	68
161104	73	302020	78	700025	69
161105	73	302056	35	700027	69
161106	73	302507	78	700478	70
161107	73	302509	78	700578	70
161109	73	302511	78	700678	70
161156	73	302512	78	700778	70
161206	73	302516	78	700978	70
161207	73	302520	78	701178	70
161209	73	302525	78	701278	70
161211	73	303107	78	701678	70
161256	73	303109	78	702080	70
161611	73	303111	78	702580	70
161612	73	303112	78	703180	70
165604	73	303116	78	705678	70
165605	73	303120	78	709478	71
230400	78	303125	78	709480	71

Art. No.	Page	Art. No.	Page
730025.....	70	751235.....	69
730027.....	70	751635.....	69
745533.....	89	752035.....	69
745540.....	88	752535.....	69
745551.....	86	753135.....	69
745562.....	86	755635.....	69
745564.....	89		
745565.....	88		
745566.....	87		
745582.....	86		
745723.....	87		
747342.....	46		
747343.....	46		
747382.....	47		
747383.....	47		
747540.....	54		
747541.....	54		
747544.....	48		
747545.....	48		
747546.....	50		
747547.....	50		
747548.....	52		
747549.....	52		
747550.....	60		
747551.....	61		
747552.....	63		
747554.....	62		
747580.....	55		
747581.....	55		
747584.....	49		
747585.....	49		
747586.....	51		
747587.....	51		
747588.....	53		
747589.....	53		
747590.....	87		
747591.....	67		
747592.....	67		
747711.....	57		
747712.....	57		
747713.....	56		
747723.....	58		
747733.....	88		
747800.....	64		
747801.....	66		
747802.....	64		
747803.....	66		
747808.....	64		
749040.....	54		
749041.....	54		
749044.....	48		
749045.....	48		
749046.....	50		
749047.....	50		
749048.....	52		
749049.....	52		
749051.....	61		
749053.....	60		
749054.....	62		
749342.....	46		
749343.....	46		
749711.....	58		
749713.....	56		
749722.....	59		
749733.....	88		
749800.....	65		
749801.....	66		
749808.....	22		
750435.....	69		
750535.....	69		
750635.....	69		
750735.....	69		
750935.....	69		
751135.....	69		

Aliaxis Nederland B.V.

Industrieterrein 11
NL-5981 NK Panningen
The Netherlands
Tel: +31 (0)77 30 88 650
info@akason.com
www.akason.com

