

Vinidex
by **alixis**



Philmac

PUSH
Push. Done.

Technical Manual



Benefits	2
Standards	3
Product Specifications	3
Installation Instructions	4
System Design Considerations	5
Chemical Resistance Chart	6
Materials & Components	7
Principals of Operation	7
Range Dimensions & Weights	8



Philmac is well renowned for quality products and services. Philmac manufactures pipe fittings and valves under a Quality Assurance System assessed and approved to ISO 9001. Philmac has a NATA accredited laboratory and tests fittings and valves to international and national standards. Third party accreditation is carried out by SAI Global.

Disclaimer

Please note that the information, opinions, recommendations and advice given in this manual are supplied only to provide an improved understanding of the technical aspects of fitting systems. So far as the law allows, Philmac Pty Ltd will not accept liability in respect of any loss or damage of any kind claimed to arise as a result of reliance upon any information claimed in this manual. Please refer to our Terms and Conditions of sale.

Standards

Philmac Push is a complete range of mechanical fittings designed to make connections simple when joining metric PE pipes.

Philmac Push is designed to comply with the requirements of the following standards:

AS/NZS4129

Fittings for polyethylene pressure pipe systems.

AS/NZS 4020

Products for use in contact with water intended for human consumption with regards to their effect on the quality of water.

ISO7.1

Pipe threads where pressure joints are made on the threads.

Philmac Push connects pipe that conforms to - AS/NZS4130, Polyethylene pipes for pressure applications.

Products comply with the lead-free requirements of the national construction code - volume 3.

Product Specifications

Fittings For PE To PE Pipe Connection

Guidelines for the specifications of Philmac Push compression fittings.

Manufacturer Accreditation

Fittings are manufactured to comply with the ISO9001 Quality System.

Product Performance Accreditation

Fittings for Polyethylene (PE) pipes meet the applicable performance requirements of AS/NZS 4129 with specific reference to:

- Pressure Testing (ISO 3458)
- External Pressure resistance testing (ISO 3459)
- Resistance to pull out of test assemblies at 20 degrees C (ISO 3501)
- Internal pressure resistance when subjected to bending stresses (ISO 3503)

Threaded ends of fittings are tapered and conform to ISO7.1 [specification for pipe threads for tubes and fittings where pressure tight joints are made on threads].

Product Material Accreditation

Performance verification has been conducted according to test parameters outlined in Clause 1.12.2 and 2.4.3 if AS/NZS 4129 - Verification of long term behaviour.

Fittings are suitable for the conveyance of drinking water and conform to AS4020 [products for use in contact with water intended for human consumption with regards to their effect on the quality of water].

Product Configuration/ Material Overview

Fittings are of the compression fitting type.

Fitting bodies are of polypropylene material and the collet, spacer and grip ring is acetal material. Each fitting are supplied complete and pre-assembled with captivated collet, spacer and grip ring and seal inside the body.

O-rings shall be made of EPDM.

Fitting body colour is black so as to minimise potential light transmission and/or UV degradation.

Method of Connection

To achieve a leak proof joint, the pipe is pushed through the collet, grip ring and o-ring pre-assembled inside the fitting's body, till it reaches the internal end stop which provides positive installation feedback. The collet and grip ring is engineered with a reverse-taper design providing axial end-load resistance by producing sharp indentations that effectively lock the pipe into the fitting body.

Disassembly & Reassembly

To disassemble, simply loosen the nut. The only tool you might need is a standard wrench.

Any pipe preparation will be limited to cutting and cleaning of pipe [for foreign material or burrs]. Fittings do not require the pipe to be lubricated or chamfered during installation.

Installation Instructions



1. Cut pipe square and to required length using the flange on the central body as a guide. Ensure end of connecting pipe is undamaged and clean.



2. The fitting is pre-assembled and ready to use.



3. Take the pipe and insert it into the fitting, you'll feel it hitting the internal stop once it pushes past o-ring, it's now fully installed.

Disassembly & Reassembly



4. To disassemble, simply loosen the nut. The only tool you might need is a standard wrench.



2. When you remove the nut all the components become loose and the pipe can be removed.



3. Firstly take the o-ring and place in the body



4. Then take your spacer and again place in fitting body.



5. Take the grip ring ensuring it is orientated correctly with the gripper teeth pointing downwards.



6. Take split ring, placing it on top of the grip ring with the taper facing up



7. Put the nut back onto the body, tighten up by hand.



8. Ensure the nut meets the flange. The fitting is now ready for re-use.



System Design Considerations

There are generally three types of PE pipe fittings; mechanical, push and thermofusion. Philmac Push™ is a range of push fittings that offers three distinct advantages over thermofusion fittings;

- **Less insertion force enabling quick and easy installation**
- **Quick installation, hence more economical**
- **Disassembly and Reassembly enabling the reuse**
- **Depth of pipe installation till the end stop providing positive installation feedback**

This section highlights engineering considerations when designing a PE pipe system with Philmac Push™.

Head losses

The following table offers a guide in estimating head losses in PE pipe systems based on the conveyance of water. Use the following formula to estimate this head loss;

$$L = F \times D$$

where F = fitting constant

D = pipe inner diameter [m]

L = head loss based on equivalent pipe length [m]

Fitting	Fitting Constant (F)
90° elbow	30
90° tee - straight through	12
90° tee - side branch	60

Resistance to Impact

The thermoplastic materials used in the Philmac Push™ fitting have excellent impact properties

Abrasion resistance

Philmac Push™ is suitable for the transportation of abrasive slurries and will withstand normal conditions found in urban, mining, industrial, rural water and waste water systems

Weathering

The materials used contain pigments to provide excellent protection to degradation due to ultra-violet radiation. Continuous use of the Philmac Push™ fitting in systems above ground is therefore permissible without additional protection.

Electrolytic Corrosion

Philmac Push™ is non magnetising and does not cause electrolytic deterioration.

Thermal Insulation

Polypropylene has natural thermal insulation of 2000 times over copper and 200 times over steel.

Light Transmission

The all black Philmac Push™ does not transmit light, thus protecting the water quality in potable water pipelines from growth of micro organisms.

Effect on Water

Philmac Push™ does not impart to water any odour, taste, colour, or any constituents in concentrations that could be injurious to health.

Fluids other than Water

Philmac Push™ may convey a wide variety of fluids. The following table is provided as a guide only for the compatibility of various chemicals to Philmac Push™. Contact Philmac for advice on specific applications.

Temperature

Philmac Push fittings are designed for cold water applications only. Exposure to elevated temperatures has a significant impact on the lifetime of the fittings. The minimum 50 year life specification for the fitting is based on an operating temperature of 23 degrees Celsius.

Chemical Resistance

Chemical	Compatibility	Chemical	Compatibility
Acetic Acid [10%]	✓	Lubricating Oils	X
Acetone	✓	Magnesium Nitrate	✓
Alcohol [Ethanol]	✓	Magnesium Sulphate	✓
Ammonium Hydroxide	✓	Methane	X
Ammonium Nitrate	✓	Methylene Chloride	X
Antifreeze [<50% concentration]	X	Mineral Oils	X
Benzene	X	Nitric Acid	X
Brine	✓	Olive Oil	X
Calcium Carbonate	✓	Petroleum Oils	X
Calcium Chloride	✓	Phosphoric Acid [<30% aqueous]	✓
Calcium Nitrate	✓	Potable Water	✓
Calcium Sulphate	✓	Potassium Chloride	✓
Caustic Soda [<40% aqueous]	✓	Potassium Nitrate	✓
Chlorine Water	X	Sewerage	✓
Citric Acid [10% aqueous]	✓	Sodium Bicarbonate	✓
Compressed Air	✓	Sodium Cyanide	✓
Copper Chloride	✓	Sodium Hypochlorite [<10%]	
Copper Sulphate <5%]	✓	Sulphuric Acid [<40% aqueous]	✓
Cresol	X	Toluene	X
Diesel	X	Turpentine	X
Formic Acid	✓	Urea [<30% aqueous]	✓
Gasoline	X	Zinc Nitrate	✓
Hydrochloric Acid [10%]	✓	Zinc Sulphate	✓
Kerosene	X		

Empty Cell=No data available
Note recommendations based on fluids at 20° C or less



Materials & Components

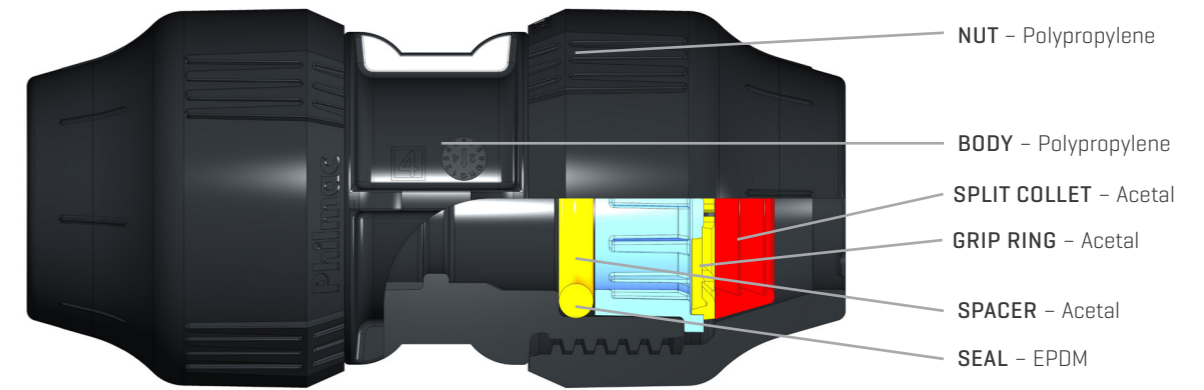

Principals of Operation

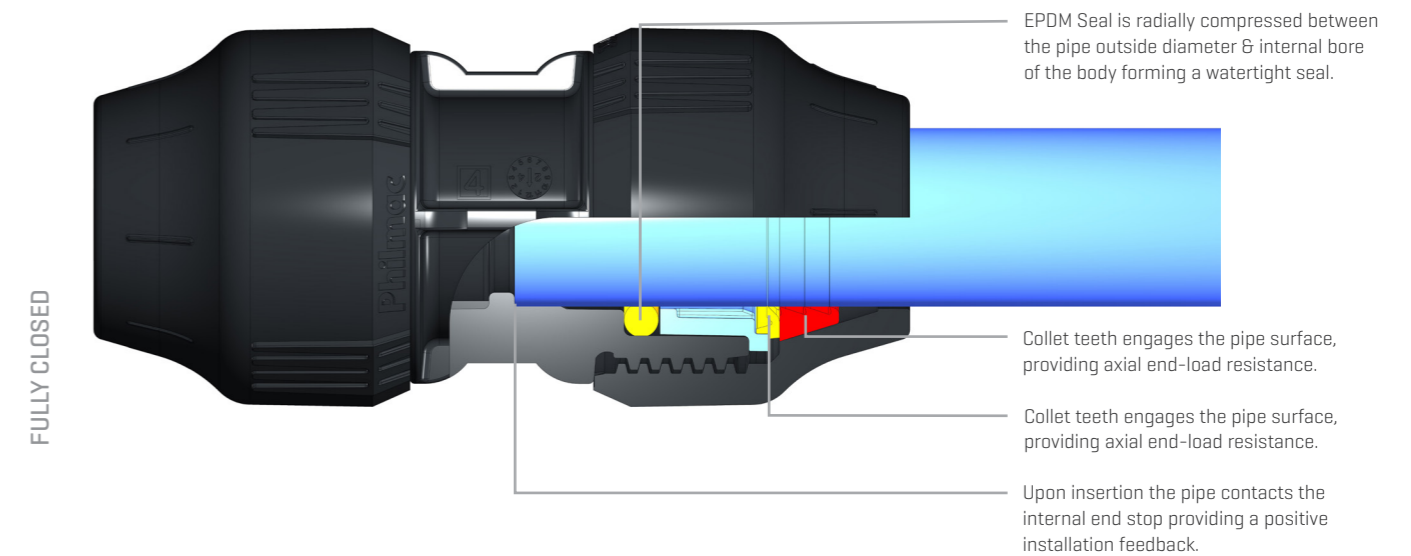
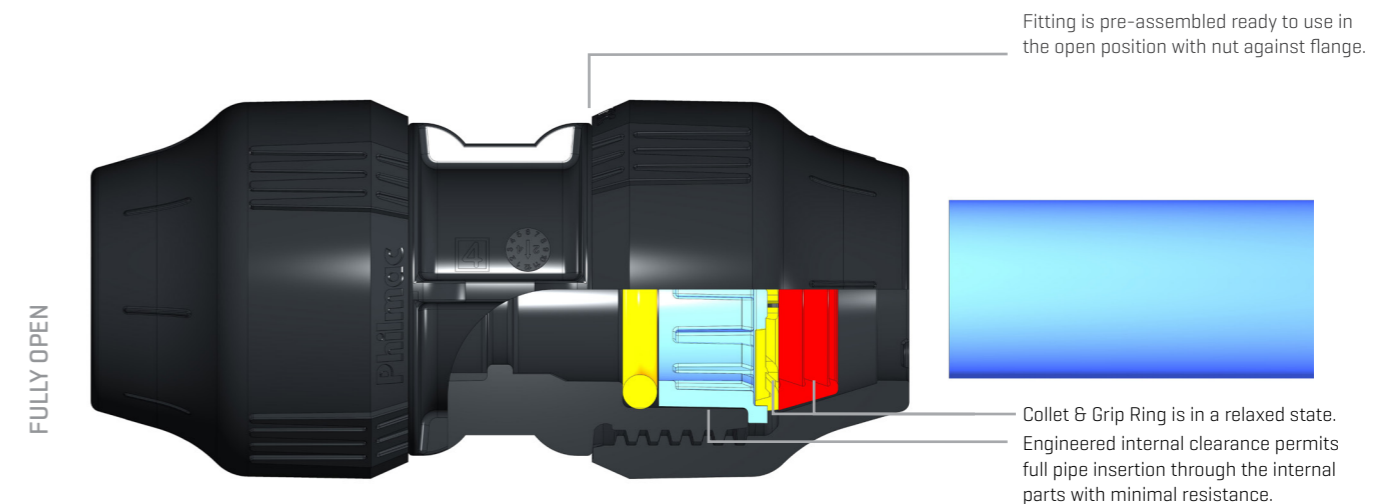

Range Dimensions & Weights

JOINERS

[Metric X Metric]

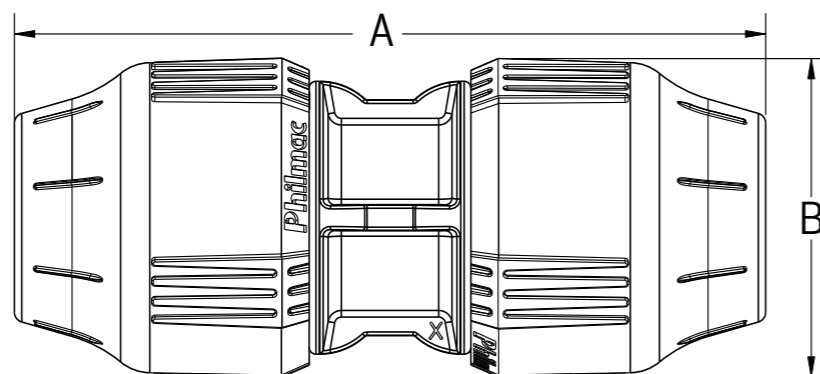

Product No.	Size	Dimensions mm.		kg.
		A	B	
74 7122 00	20 x 20	111.5	48.9	0.087
74 7133 00	25 x 25	119.2	57.8	0.129
74 7144 00	32 x 32	147.7	70.5	0.214
74 7155 00	40 x 40	173	84.2	0.384
74 7166 00	50 x 50	203.3	97.2	0.565
74 7177 00	63 x 63	234	112.2	0.848

REDUCING JOINERS

[Metric X Metric]

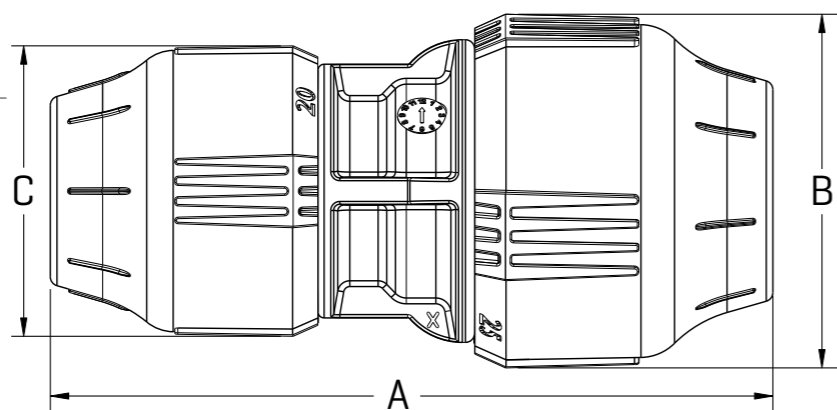

Product No.	Size	Dimensions mm.			kg.
		A	B	C	
74 7132 00	25 x 20	118.2	57.8	48.9	0.114
74 7142 00	32 x 20	132.2	70.5	48.9	0.158
74 7143 00	32 x 25	134.3	70.5	57.8	0.181
74 7174 00	63 x 32	207.4	112.3	70.5	0.560



Range Dimensions & Weights

MALE END CONNECTORS

[Metric X MI BSP]

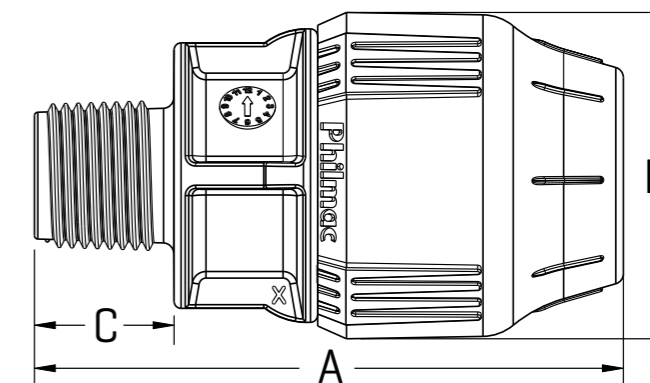

Product No.	Size	Dimensions mm.			kg.
		A	B	C	
74 7221 00	20 x 1/2"	84.3	48.9	20.0	0.052
74 7222 00	20 x 3/4"	85.3	48.9	21.0	0.053
74 7231 00	25 x 1/2"	93.3	57.8	20.0	0.081
74 7232 00	25 x 3/4"	89.1	57.8	18.0	0.075
74 7233 00	25 x 1"	98.9	57.8	24.7	0.085
74 7242 00	32 x 3/4"	105.0	70.5	21.0	0.127
74 7243 00	32 x 1"	108.0	70.5	24.0	0.124
74 7244 00	32 x 1-1/4"	111.0	70.5	27.0	0.136
74 7245 00	32 x 1-1/2"	110.2	70.5	26.7	0.138
74 7253 00	40 x 1"	124.5	84.2	24.0	0.222
74 7254 00	40 x 1-1/4"	127.5	84.2	26.7	0.225
74 7255 00	40 x 1-1/2"	127.0	84.2	26.7	0.226
74 7265 00	50 x 1-1/2"	137.9	97.2	26.7	0.325
74 7266 00	50 x 2"	142.9	97.2	31.0	0.335
74 7275 00	63 x 1-1/2"	156.0	112.2	26.7	0.509
74 7276 00	63 x 2"	162.0	112.2	31.0	0.515



Range Dimensions & Weights

FEMALE END CONNECTORS

[Metric X MI BSP]

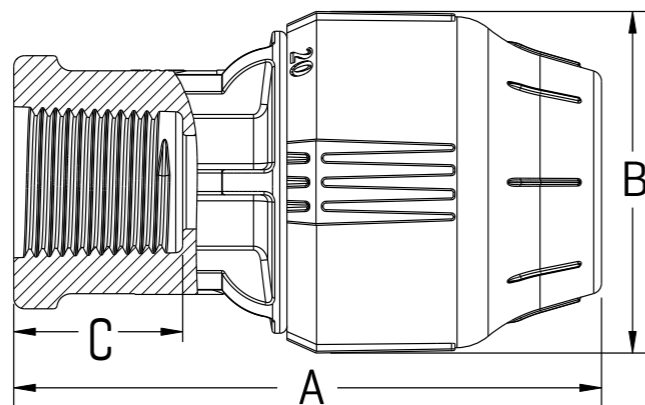

Product No.	Size	Dimensions mm.			kg.
		A	B	C	Wt
74 7821 00	20 x 1/2"	81.75	48.9	23.5	0.058
74 7822 00	20 x 3/4"	80.25	48.9	22.5	0.058
74 7831 00	25 x 1/2"	86.6	57.8	22.5	0.077
74 7832 00	25 x 3/4"	85.8	57.8	24	0.078
74 7833 00	25 x 1"	89.75	57.8	27.4	0.089
74 7842 00	32 x 3/4"	106.5	70.5	24.1	0.148
74 7843 00	32 x 1"	101.95	70.5	27.4	0.139
74 7844 00	32 x 1-1/4"	104.45	70.5	30.2	0.141
74 7854 00	40 x 1-1/4"	118.5	84.2	30.2	0.228
74 7855 00	40 x 1-1/2"	118.5	84.2	30	0.234
74 7865 00	50 x 1-1/2"	126.92	97.2	27	0.308
74 7866 00	50 x 2"	127.9	97.2	28	0.326
74 7876 00	63 x 2"	146.84	112.2	30.4	0.478

Range Dimensions & Weights

TEES

[Metric X Metric X Metric]

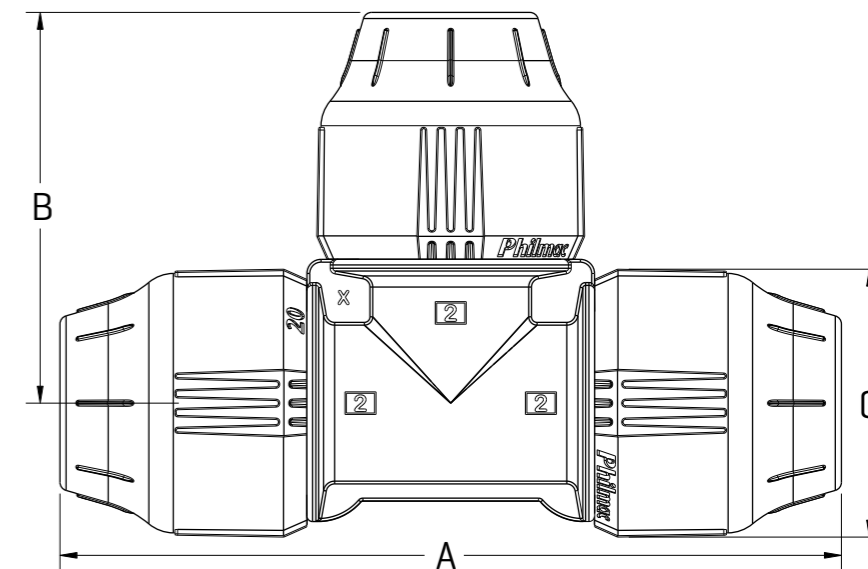

Product No.	Size	Dimensions mm.			kg.
		A	B	C	Wt
74 7322 00	20 x 20 x 20	138.58	69.3	48.9	0.142
74 7333 00	25 x 25 x 25	156.2	78.1	57.8	0.212
74 7344 00	32 x 32 x 32	182.71	91.36	70.5	0.345
74 7355 00	40 x 40 x 40	218.5	110	84.2	0.618
74 7366 00	50 x 50 x 50	245.05	122.2	97.2	0.851
74 7377 00	63 x 63 x 63	289.64	144.82	112.2	1.417



Range Dimensions & Weights

REDUCING TEES

[Metric X Metric X MI BSP]

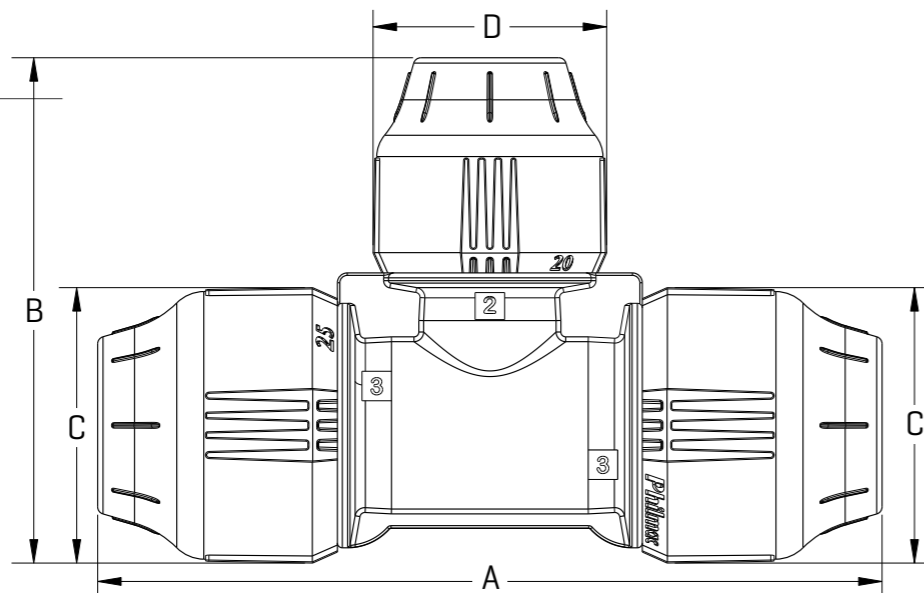

Product No.	Size	Dimensions mm.				kg.
		A	B	C	D	
74 7332 00	25 x 25 x 20	159.5	102.75	57.8	48.9	0.197
74 7343 00	32 x 32 x 25	187.9	121	70.5	57.9	0.321

FEMALE TEES

[Metric X Metric X FI BSP]

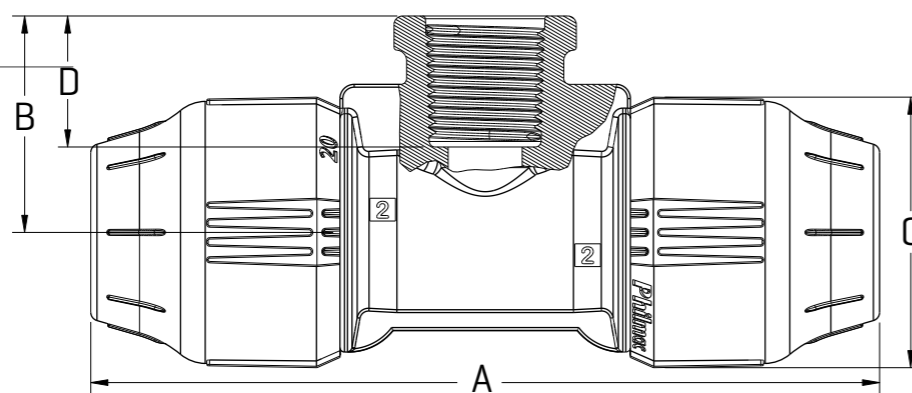

Product No.	Size	Dimensions mm.				kg.
		A	B	C	D	
74 7421 00	20 x 20 x 1/2"	138.5	38	48.9	23	0.072
74 7422 00	20 x 20 x 3/4"	138.5	38	48.9	23.5	0.077
74 7431 00	25 x 25 x 1/2"	143.5	39.5	57.8	22.5	0.147
74 7432 00	25 x 25 x 3/4"	159.9	40.5	57.8	24	0.169
74 7433 00	25 x 25 x 1"	159.5	43.9	57.8	27	0.174
74 7442 00	32 x 32 x 3/4"	187.9	43.6	70.5	24	0.263
74 7443 00	32 x 32 x 1"	187.9	46.5	70.5	27	0.271
74 7444 00	32 x 32 x 1-1/4"	187.9	50	70.5	29.5	0.280



Range Dimensions & Weights

ELBOWS

[Metric X Metric]

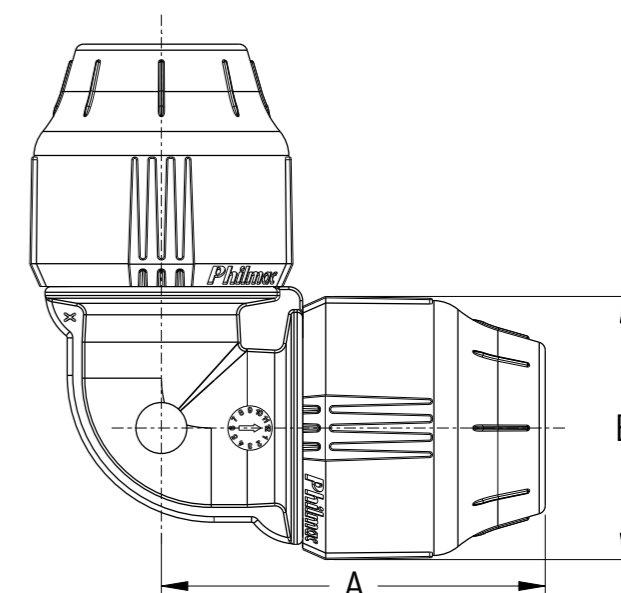

Product No.	Size	Dimensions mm.		kg.
		A	B	
74 7522 00	20 x 20	69.3	48.9	0.093
74 7533 00	25 x 25	79.8	57.8	0.152
74 7544 00	32 x 32	91.4	70.5	0.237
74 7555 00	40 x 40	109.5	84.2	0.417
74 7566 00	50 x 50	122.6	97.2	0.593
74 7577 00	63 x 63	144.8	112.2	0.934



Range Dimensions & Weights

FEMALE ELBOWS

[Metric X FI BSP]

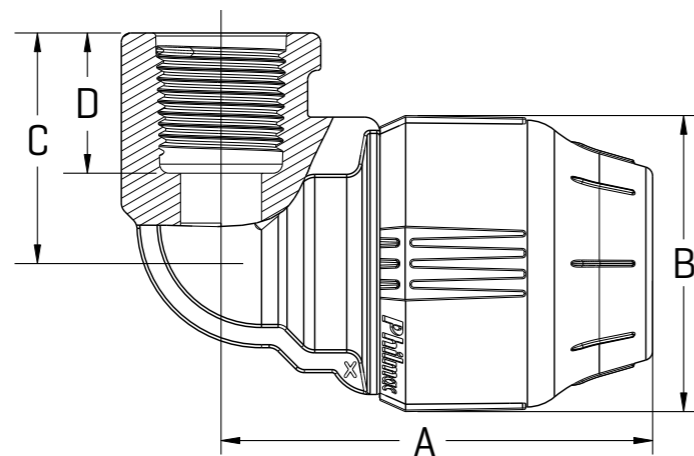

Size	Part No.	Dimensions mm.				kg.
		A	B	C	D	
74 7621 00	20 x 1/2"	69.25	48.9	37	22.5	0.056
74 7622 00	20 x 3/4"	69.25	48.9	38	24	0.062
74 7631 00	25 x 1/2"	75.11	57.8	39.5	22.8	0.079
74 7632 00	25 x 3/4"	79.75	57.8	40.63	24	0.092
74 7633 00	25 x 1"	79.75	57.8	43.93	27	0.102
74 7643 00	32 x 1"	93.95	70.5	47	27	0.146
74 7644 00	32 x 1-1/4"	94.6	70.5	50.55	30.55	0.156
70 7666 00	50 x 2"	127.42	97.2	65.55	34.55	0.403

Range Dimensions & Weights

MALE ELBOWS

[Metric X MI BSP]

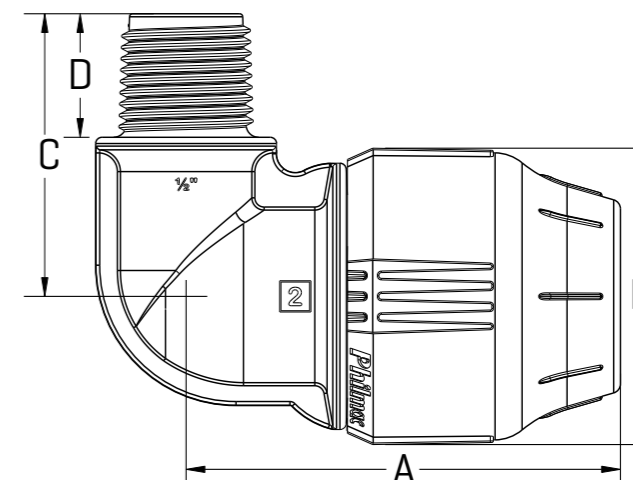

Size	Part No.	Dimensions mm.				kg.
		A	B	C	D	
74 7721 00	20 x 1/2"	69.2	48.9	43.5	19.8	0.058
74 7731 00	25 x 1/2"	77.8	57.8	49.8	20.4	0.089
74 7732 00	25 x 3/4"	77.8	57.8	51.1	20.6	0.083
74 7733 00	25 x 1"	77.8	57.8	49.5	24.5	0.093
74 7743 00	32 x 1"	89.8	70.5	56	20.4	0.147
74 7744 00	32 x 1-1/4"	94	70.5	63.7	26.7	0.168
74 7755 00	40 x 1-1/2"	109.5	84.2	69.7	27	0.275

END CAP

[Metric]

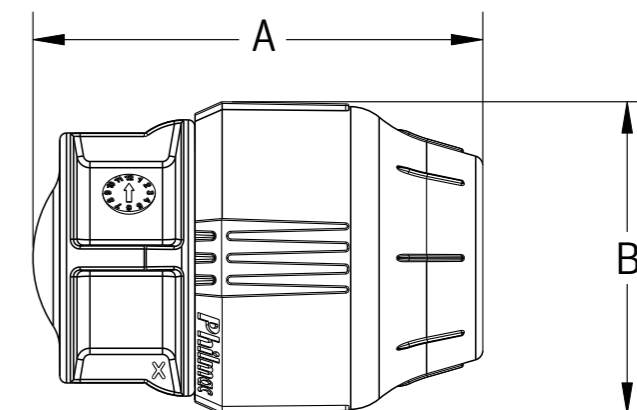

Product No.	Size	Dimensions mm.		kg.
		A	B	
74 7029 00	20	68.4	48.9	0.050
74 7039 00	25	80.7	57.8	0.078
74 7049 00	32	92.0	70.5	0.125
74 7059 00	40	110.6	84.2	0.216
74 7069 00	50	126.1	97.2	0.318
74 7079 00	63	150.3	112.2	0.488





Vinidex

by aliaxis

Vinidex Pty Limited

ABN 42 000 664 942

HEAD OFFICE

Level 4, 26 College Street
Darlinghurst NSW 2010
PO Box 747, Darlinghurst, NSW, 1300

Customer Service

Phone: 13 11 69
Fax: 13 24 43
Email: sales@vinidex.com.au
Web: www.vinidex.com.au



**SCAN TO
FIND OUT
MORE**

Limitation of Liability

This product catalogue has been compiled by Vinidex Pty Limited ("the Company") to promote better understanding of the technical aspects of the Company's products to assist users in obtaining from them the best possible performance. The product catalogue is supplied subject to acknowledgement of the following conditions:

1 The product catalogue is protected by copyright and may not be copied or reproduced in any form or by any means in whole or in part without prior consent in writing by the Company. 2 Product specifications, usage data and advisory information may change from time to time with advances in research and field experience. The Company reserves the right to make such changes at any time without further notice. 3 Correct usage of the Company's products involves engineering judgements, which can not be properly made without full knowledge of all the conditions pertaining to each specific installation. The Company expressly disclaims all and any liability to any person whether supplied with this publication or not in respect of anything and all of the consequences of anything done or omitted to be done by any such person in reliance whether whole or part of the contents of this publication. 4 No offer to trade, nor any conditions of trading, are expressed or implied by the issue of content of this product catalogue. Nothing herein shall override the Company's Condition of Sale, which may be obtained from the Registered Office or any Sales Office of the Company. 5 This product catalogue is and shall remain the property of the Company, and shall be surrendered on demand to the Company. 6 Information supplied in this product catalogue does not override a job specification, where such conflict arises; consult the authority supervising the job. © Copyright Vinidex Pty Limited.